

RaDIATE Remote Handling Tutorial

Grant Minor, P.Eng. | Remote Handling

RaDIATE Workshop

December 9-13, 2019



Vision Statement for Remote Handling

- Remote Handling at TRIUMF should ultimately endeavor to, where practicable:
 - Reduce dose to personnel working in active areas
 - Reduce the personnel resources required for tasks conducted in active areas
 - Increase reliability of tasks conducted in active areas
 - Increase flexibility of tasks conducted in active areas
 - Scheduled time / frequency of task / response time
 - Reduce the amount of active waste produced
 - Ensure compliance with the most up-to-date industrial safety standards for tasks conducted in active areas

High-Radiation Areas at TRIUMF

**ARIEL APTW /
AETE target
stations
(in design)**

**ISAC ITW / ITE
target stations**

**Proton beam
bends**

**Thermal Neutron
Facility (beam
dump)**

**T2 Target Station
T1 Target Station**

**e-Linac 10kW
tuning dump**

Cyclotron



Cyclotron Remote Handling

- Remote cantilevered service bridge mounts to cyclotron centre post
- Service trolleys move along bridge
- Multiple trolleys for different functions
 - Resonator repair / replacement
 - Remote vacuum cleaning
 - Remote welding
 - Camera and video inspection
 - Tool trolley
 - Probe service and replacement
- Bridge and trolleys operated from centralized control room

TRIUMF cyclotron



Remote cyclotron service bridge (carries trolleys into cyclotron)

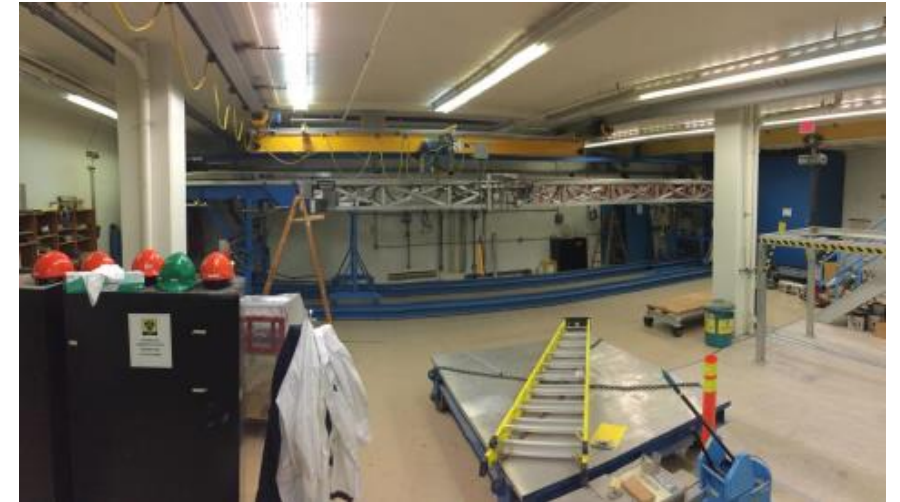

Off-line mockup test of cyclotron trolley
(HE probe service)



Cyclotron trolley in RH service shop



RH cyclotron control room

Meson Hall Remote Handling

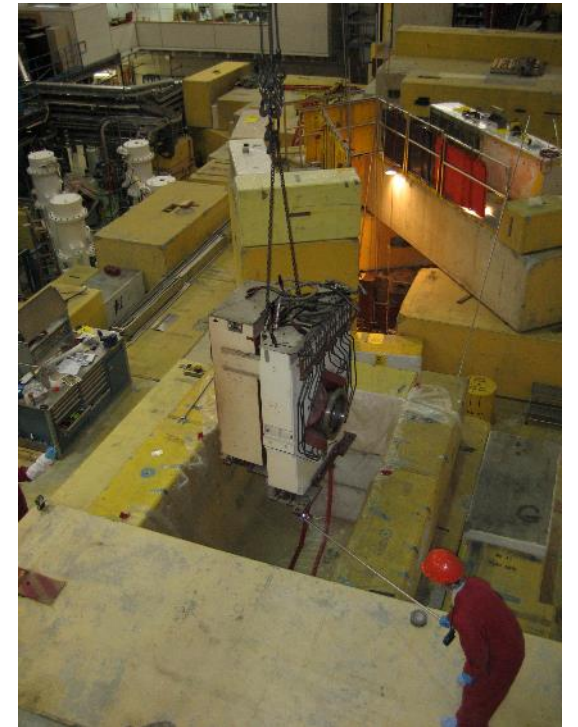

Manipulator Service and Repair

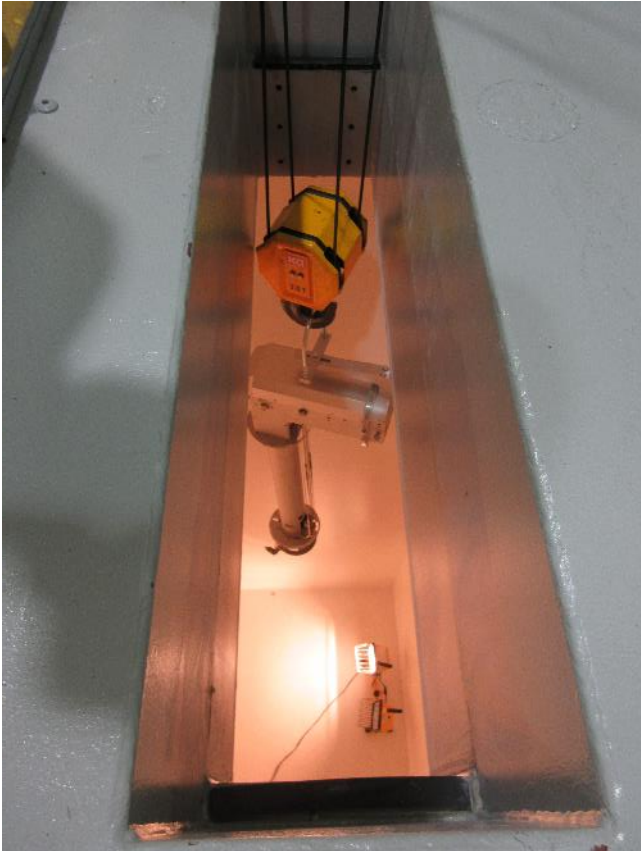
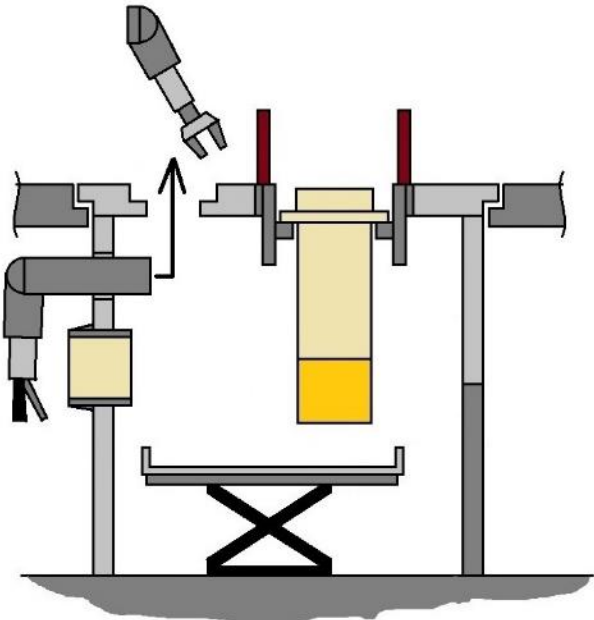

Beamlines Remote Handling

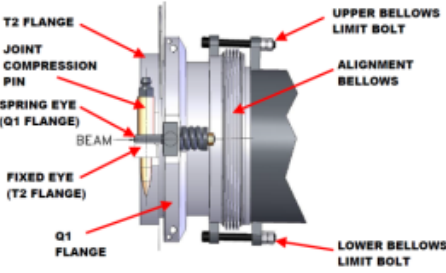

Future Development in Beamlines Remote Handling at TRIUMF

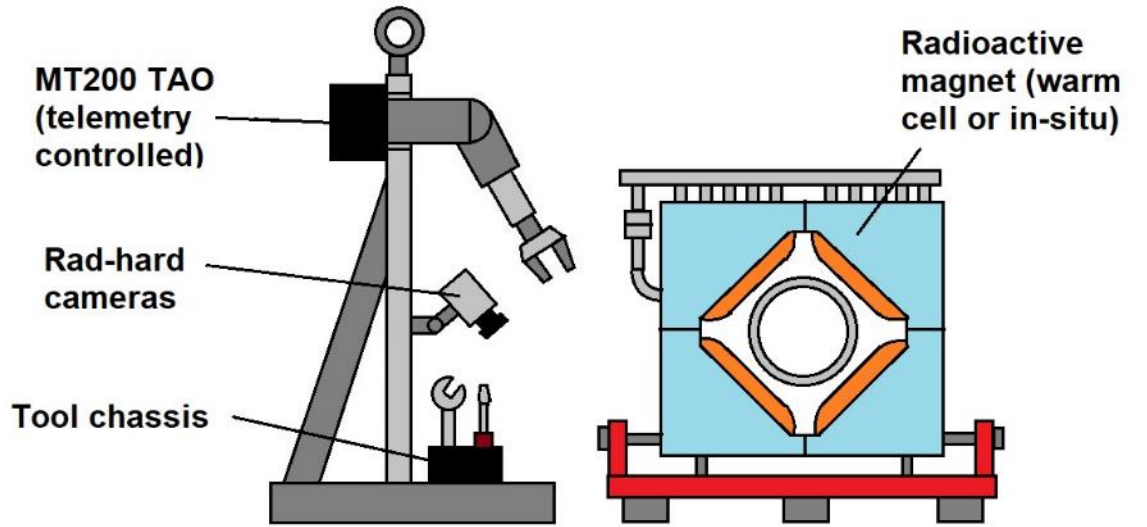

- Introduction High Power Target Handling Areas at TRIUMF
- Current ISAC Target Exchange Processes
- ISAC Target Facility Developments
- Introduction to ARIEL Target Hall Facility
- ARIEL Target Exchange System Developments

BEAM LINES AND EXPERIMENTAL FACILITIES

- In Progress
- Future

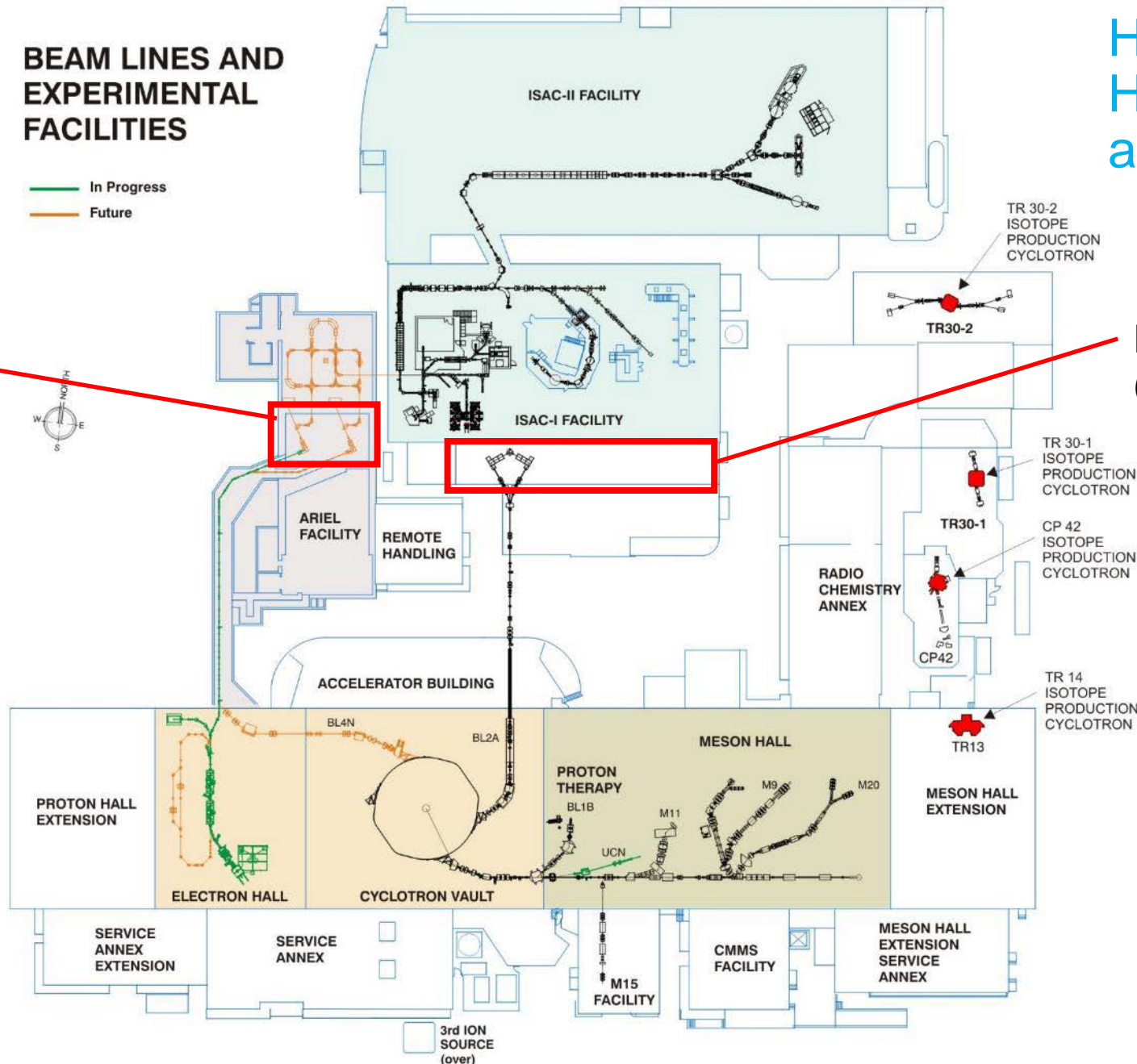

High Power Target Handling Facilities at TRIUMF

ARIEL Target Hall
(Building complete, machinery in-design, first beam ~in 2021)

ISAC Target Hall
(First beam in 2001)

ISAC Targets - Introduction

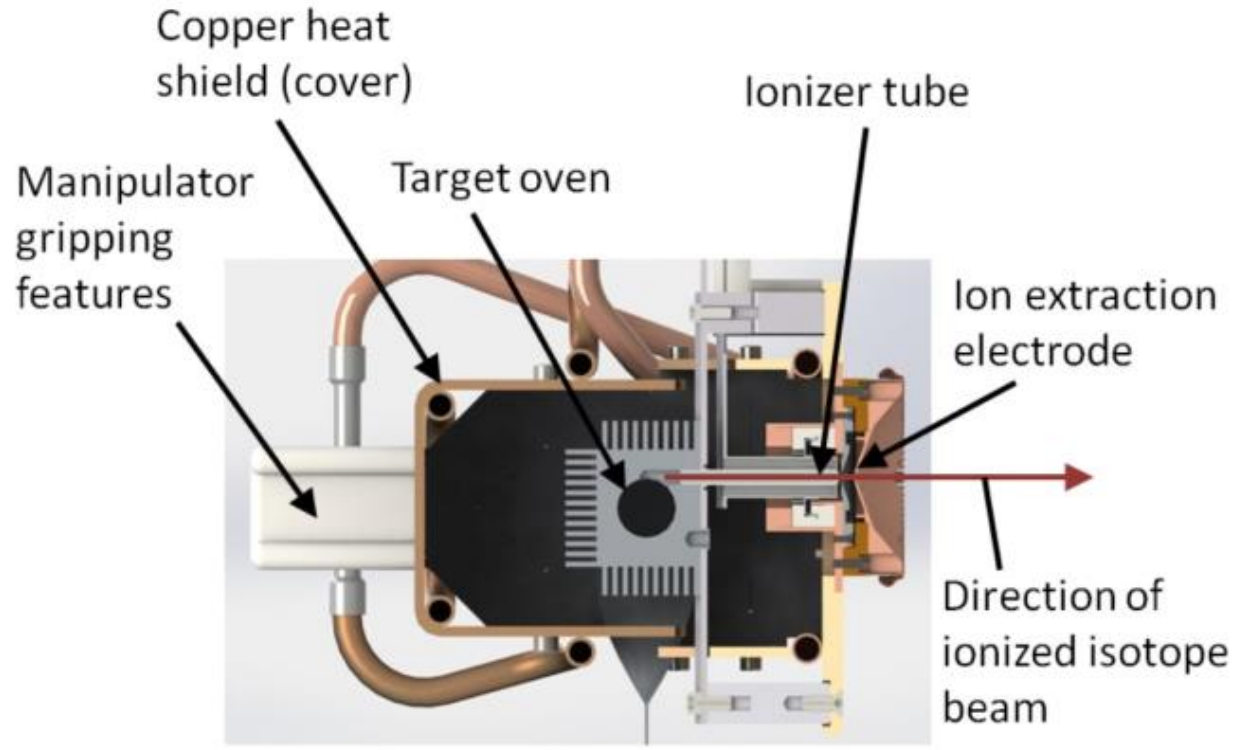
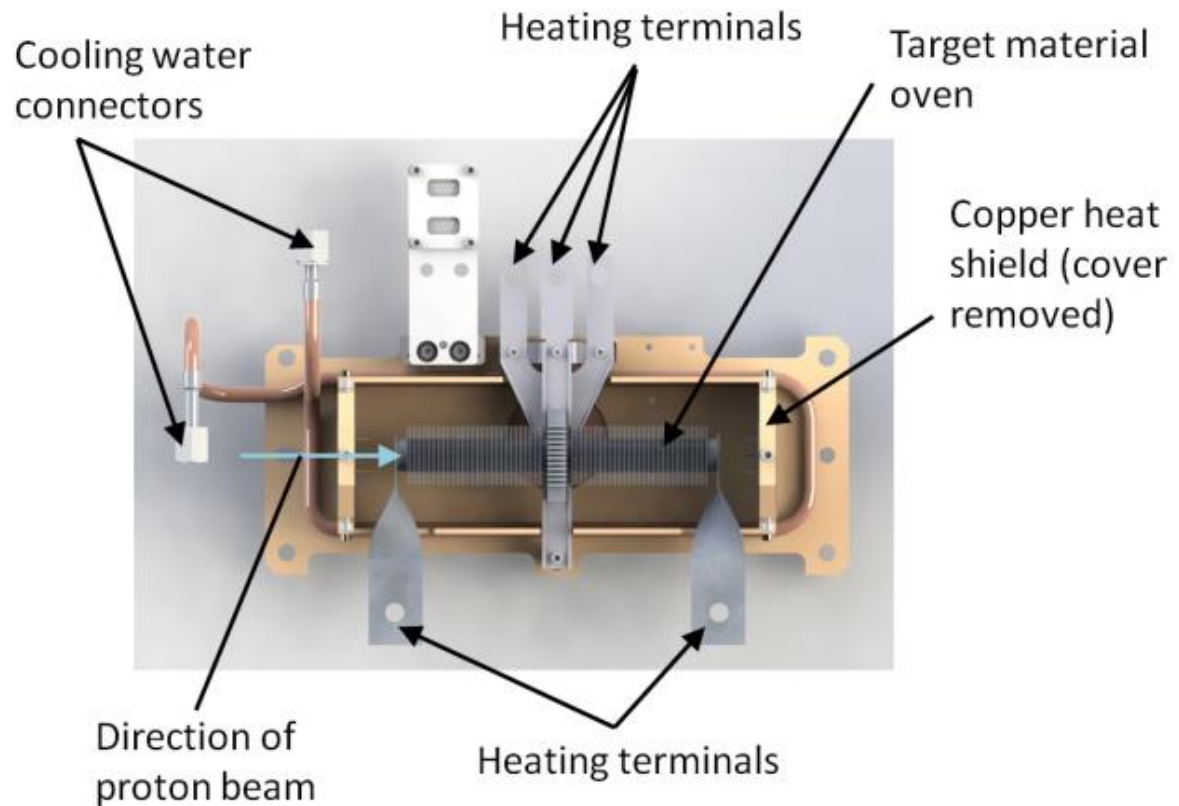

ISAC Targets Modules

**20 ton (40,000 lbs) cap.
Remote Handling Crane**

Containment Box

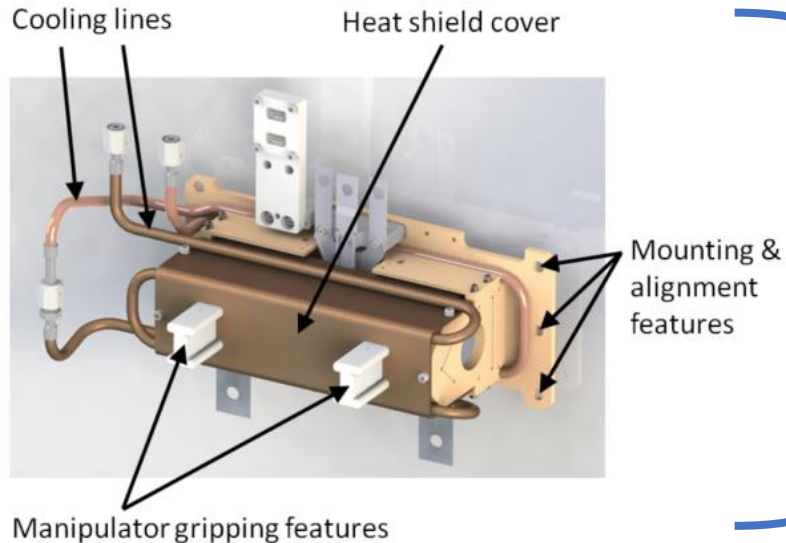

Target assembly is mounted on the extraction Front End in the Target Module containment box

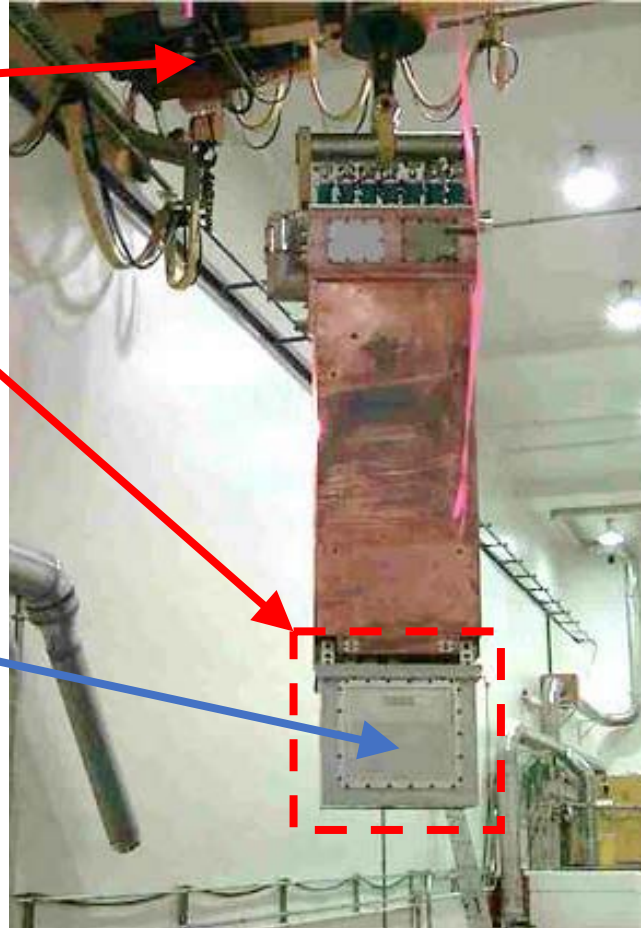

ISAC Target module hanging from remote handling crane



Target module transport to target station (remote rotation of the module is required)

ISAC Target Hall

Concrete and steel removable blocks

Remote handling crane

Target module

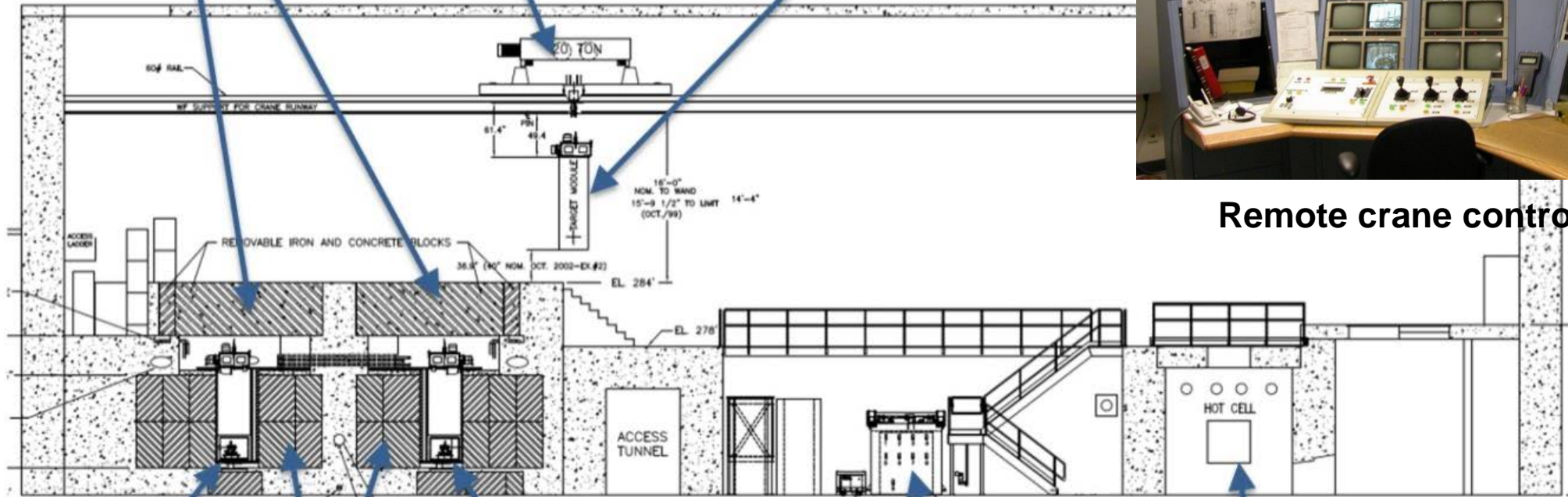

West target station

Steel shield blocks

East target station

Spent target decay storage vault

Hot cells



Remote crane control room

ISAC Target Hall

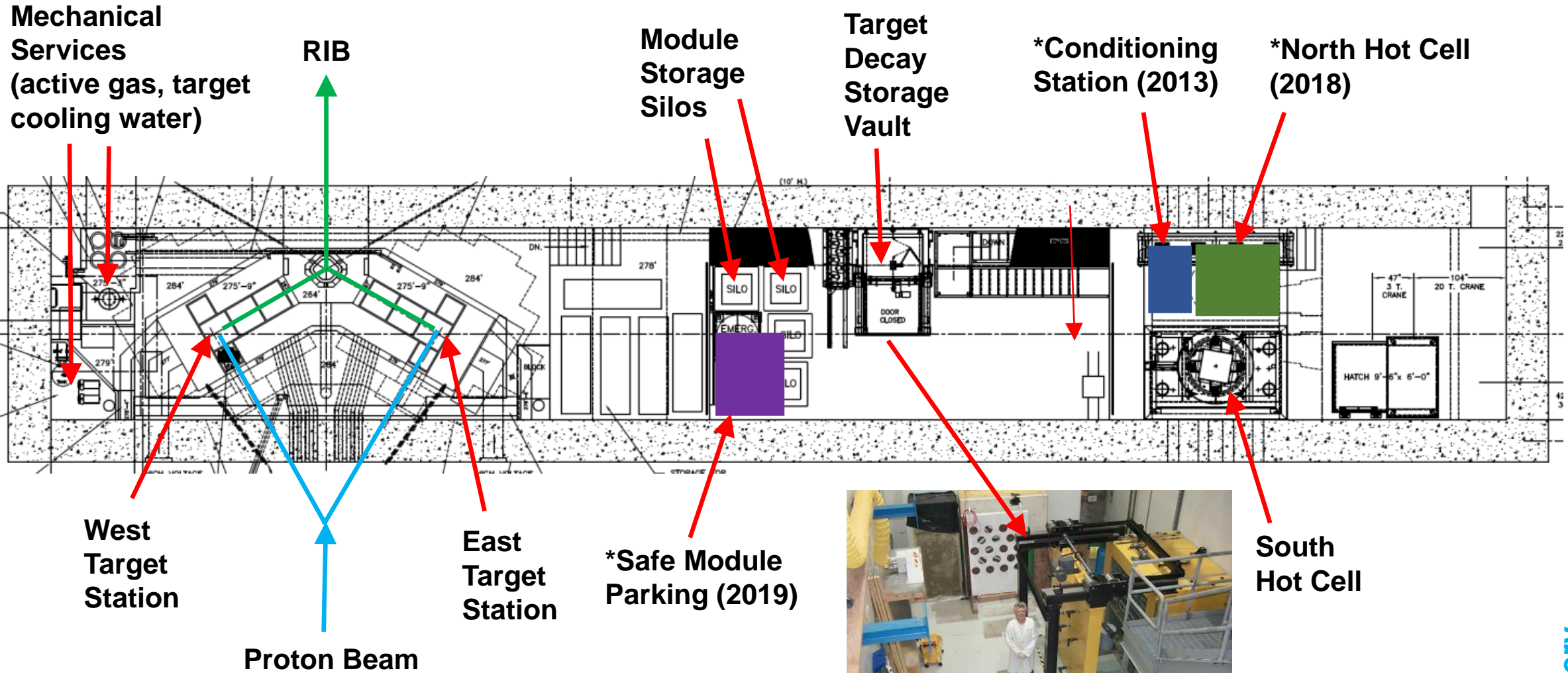

Target Hall West View

Module
storage
silos

South
hot cell

East & West
target
stations

Conditioning
station

North
hot cell

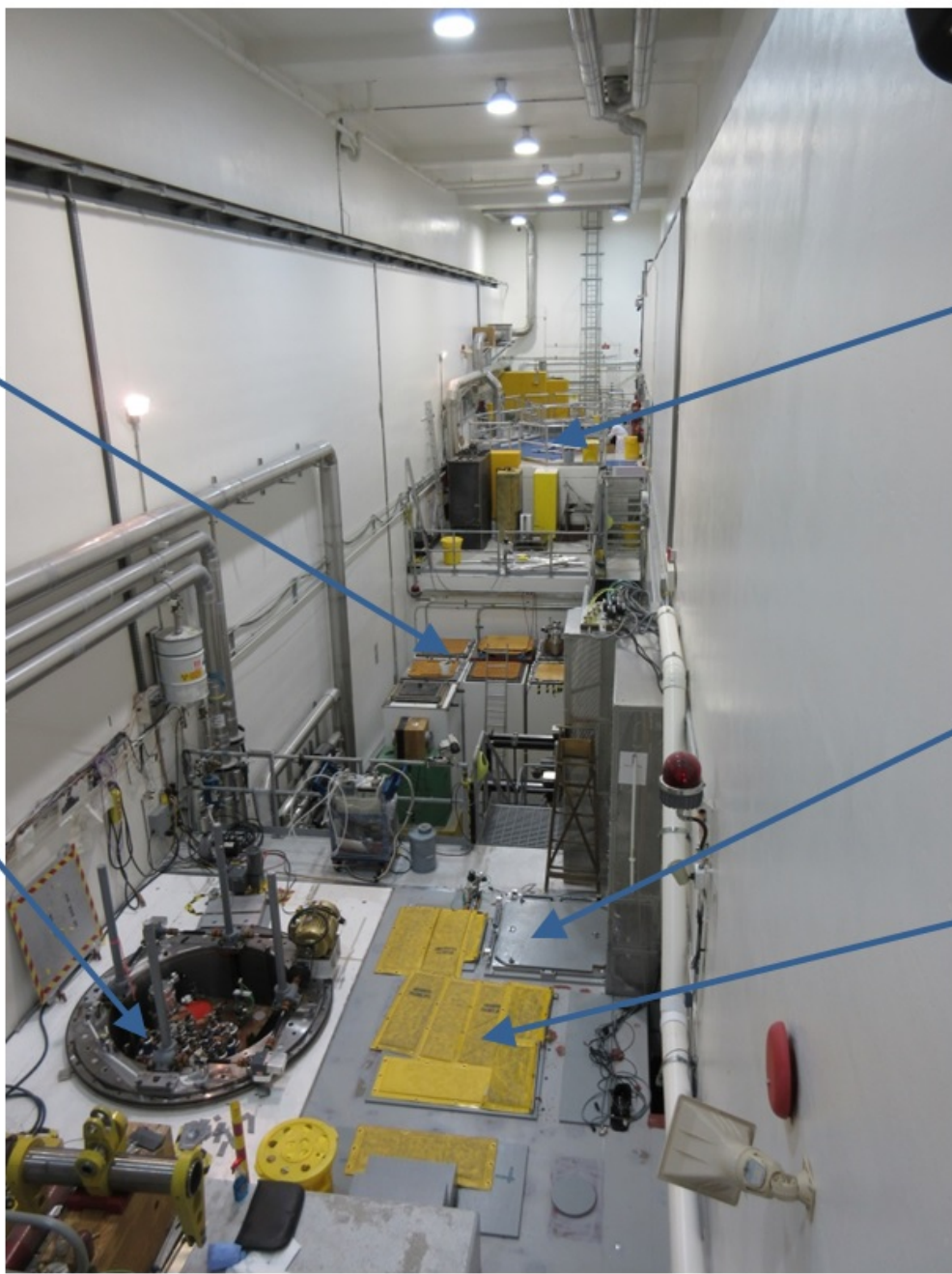

Target Hall East View



Remote handling crane



Connecting a Target Module in the pit



North and South Hot Cells

East Target Station (covered)

West Target Station

ISAC Conditioning Station (2013)

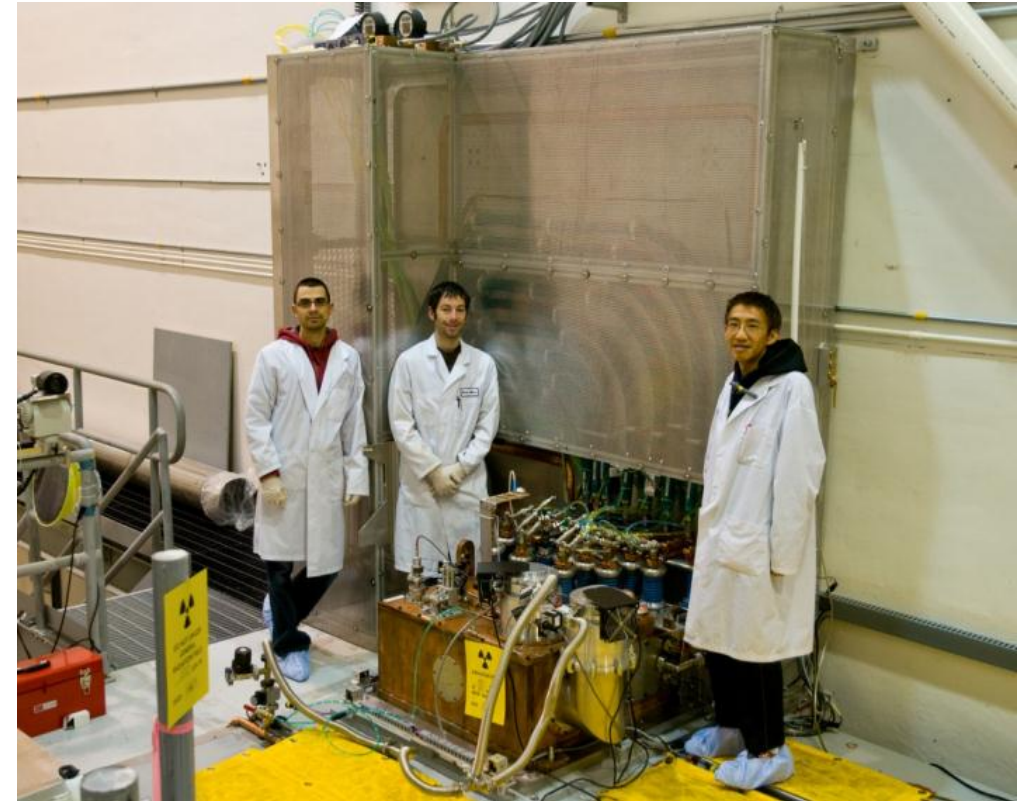
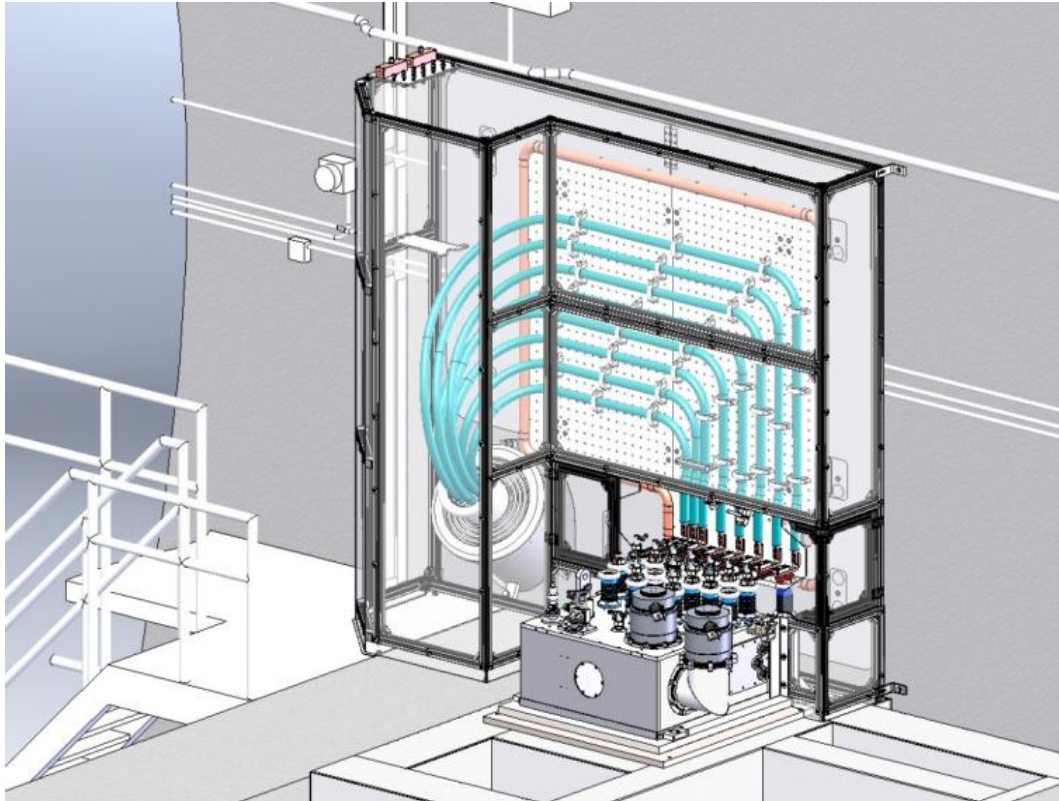

- Provides off-line vacuum vessel, high-voltage bias & high-power services for a Target Module
- Allows a target installed in a module to be conditioned and tested off-line prior to operations
- Greatly improves facility reliability through early identification of failures and off-line diagnostics

ISAC North Hot Cell (2018) – Isaac Earle

- Allows routine target exchange in parallel with repairs and development at the SHC
- Fixed module height and position (no rotation)
- Shared support structure & concrete cavity in building with Conditioning Station

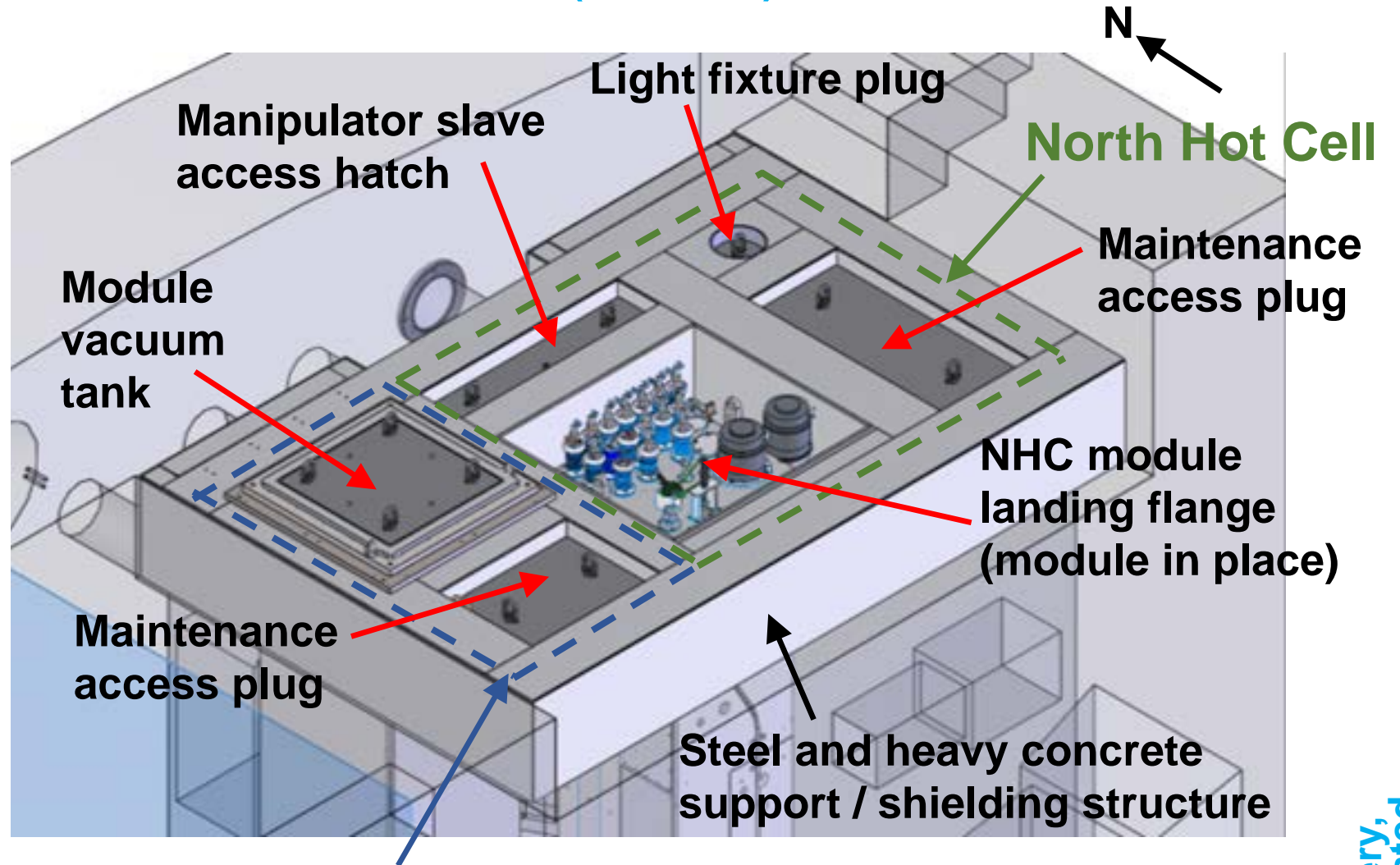

Conditioning Station

North Hot Cell – Before Start of Project



North Hot Cell – Ventilation Partition and Interior Services



Ventilation duct
(nuclear exhaust)

Pre-filter
(remote
handleable)

Conditioning
Station / NHC
partition wall

Work table with
storage hatch

Gas and
electrical
services w/
Staubli
connectors

Tool port &
shield plug

Personnel access
shield door (existing)

North Hot Cell – Interior Sealing and Finishing

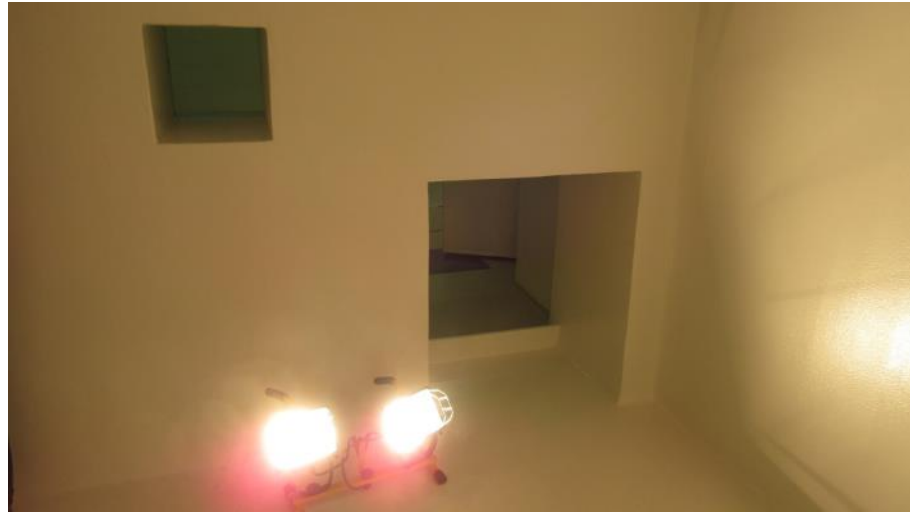
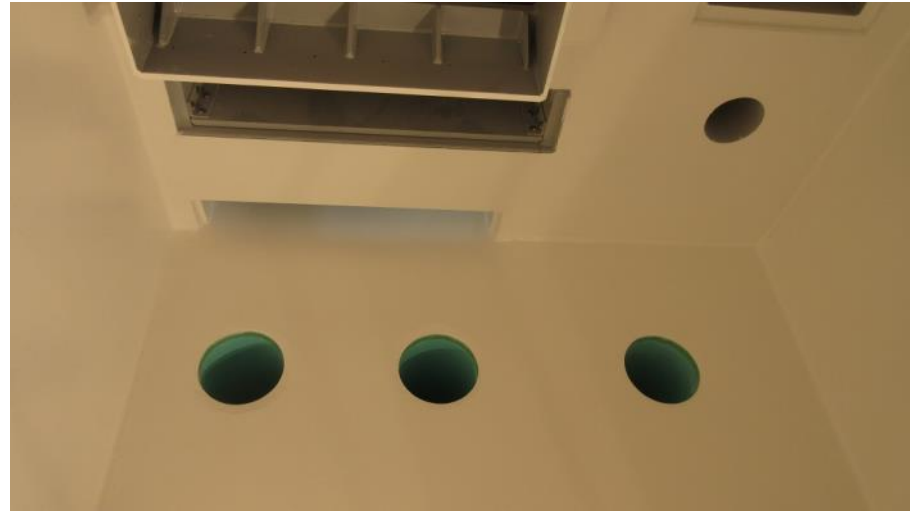
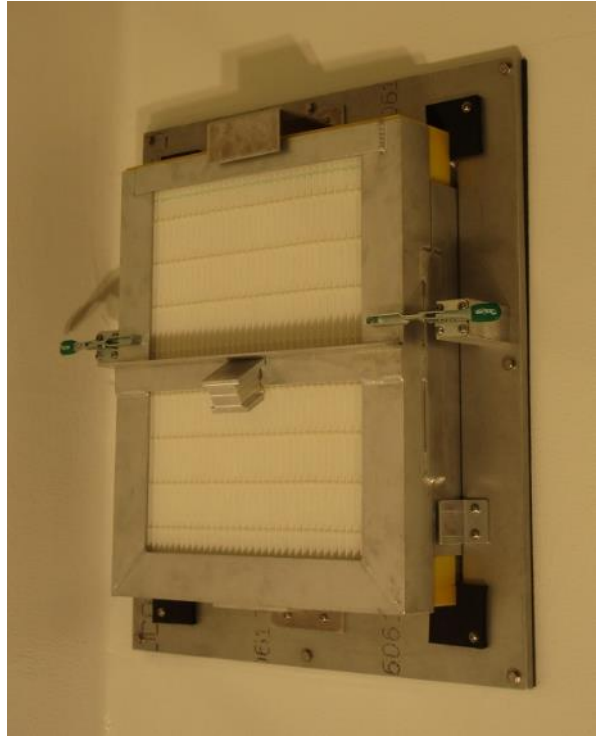

North Hot Cell – Manipulator Installation



North Hot Cell – Roof Hatch Plugs and Work Table

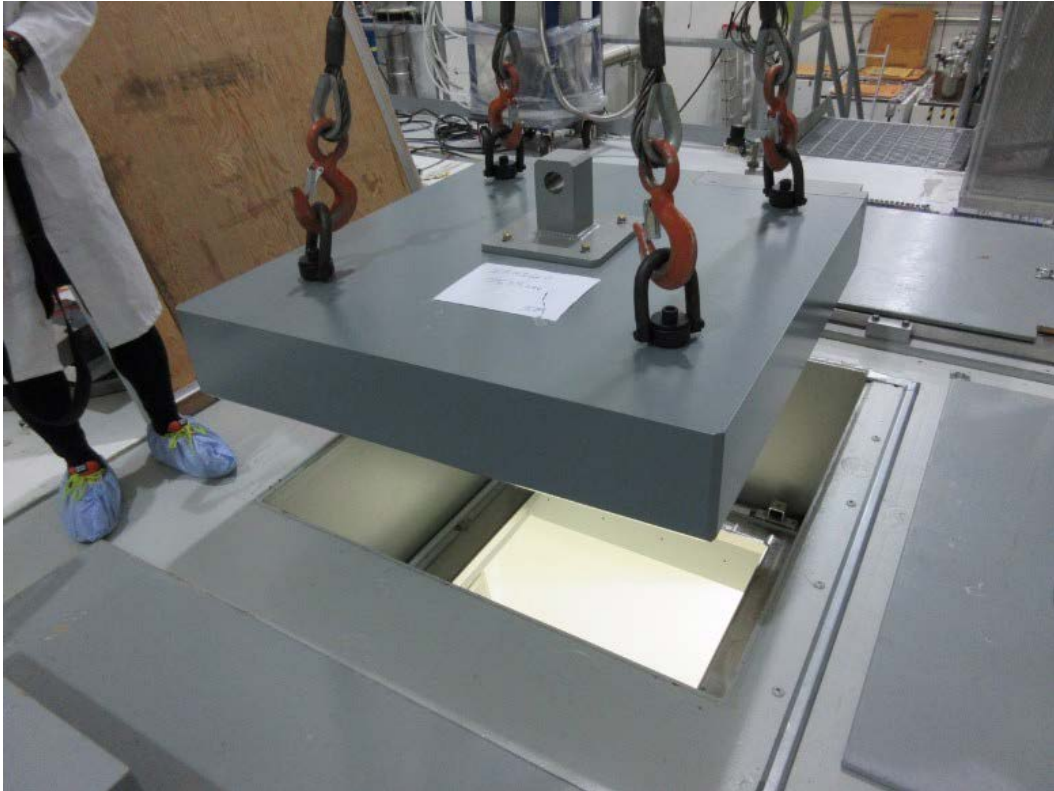

North Hot Cell – Manipulator Slave Extraction Test

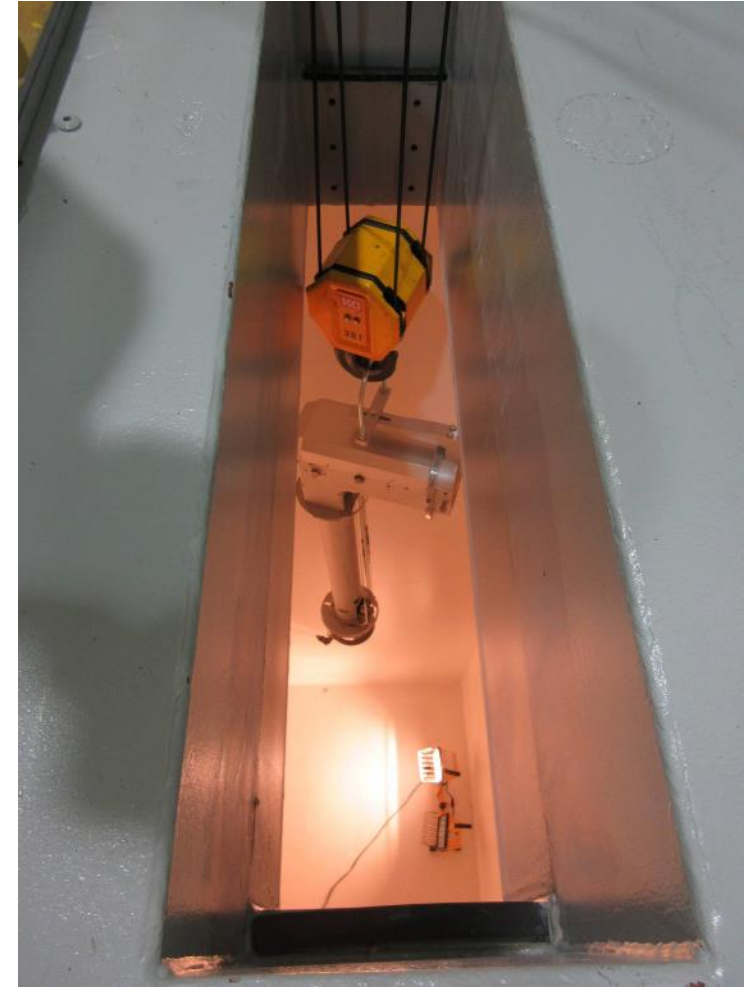

NHC Installation Photos – Project Completion

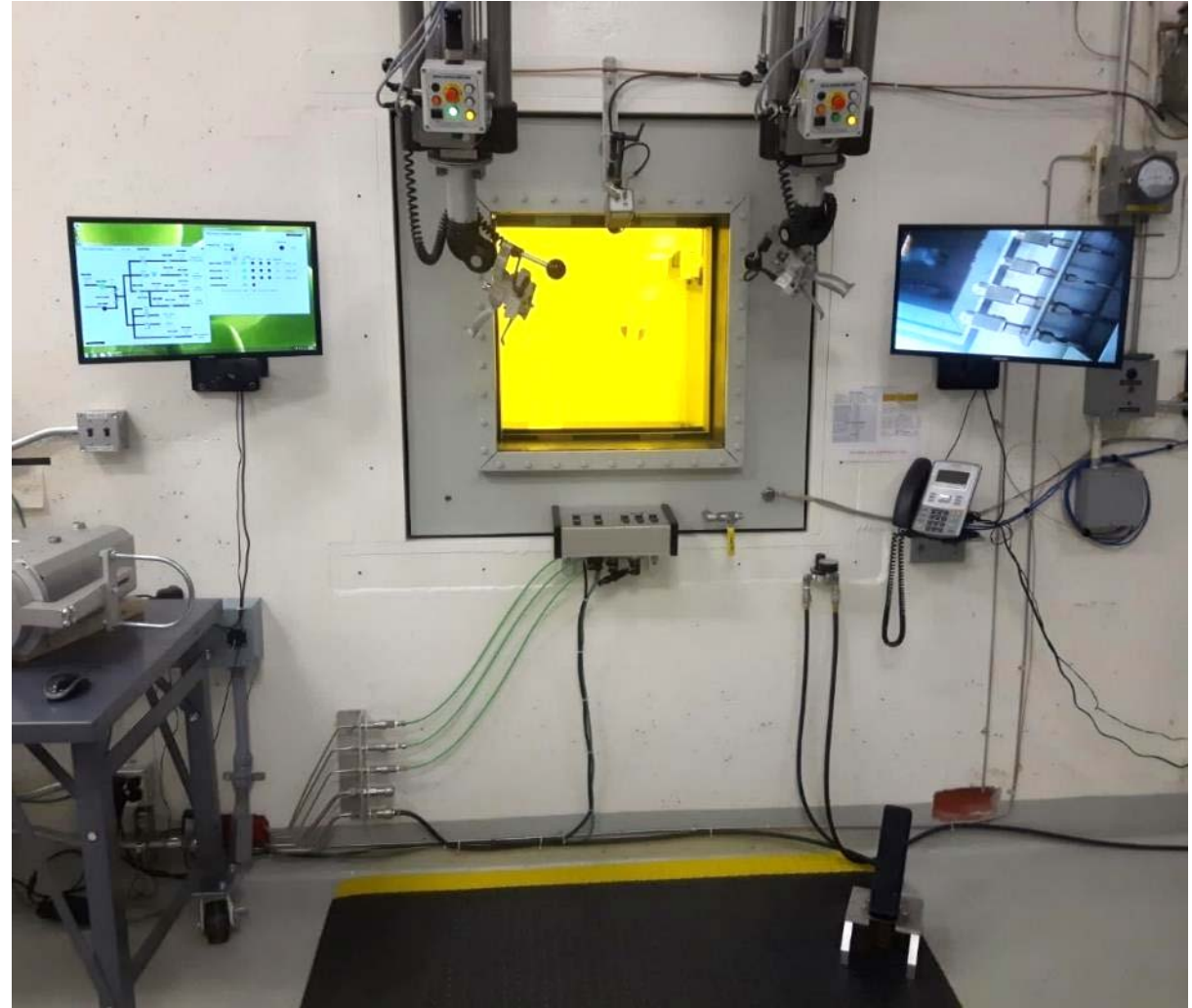

Safe Module Parking - Commissioned 2019

ISAC Module must be rotated on crane to align with Target Stations, Hot Cells, and Silos



ISAC South Hot Cell turntable currently provides backup for ISAC crane rotation machinery

- Must be vacant during a module move
- Means repair operations at SHC must be interrupted for routine module moves



Safe Module Parking:

- Provides shielded landing point for active module
- Provides mechanized rotation for crane backup
- Frees the South Hot Cell for uninterrupted long-term maintenance and repair operations



Credit

- Yasmine Saboui
- Isaac Earle

NHC Introduction – Location in ISAC Target Hall

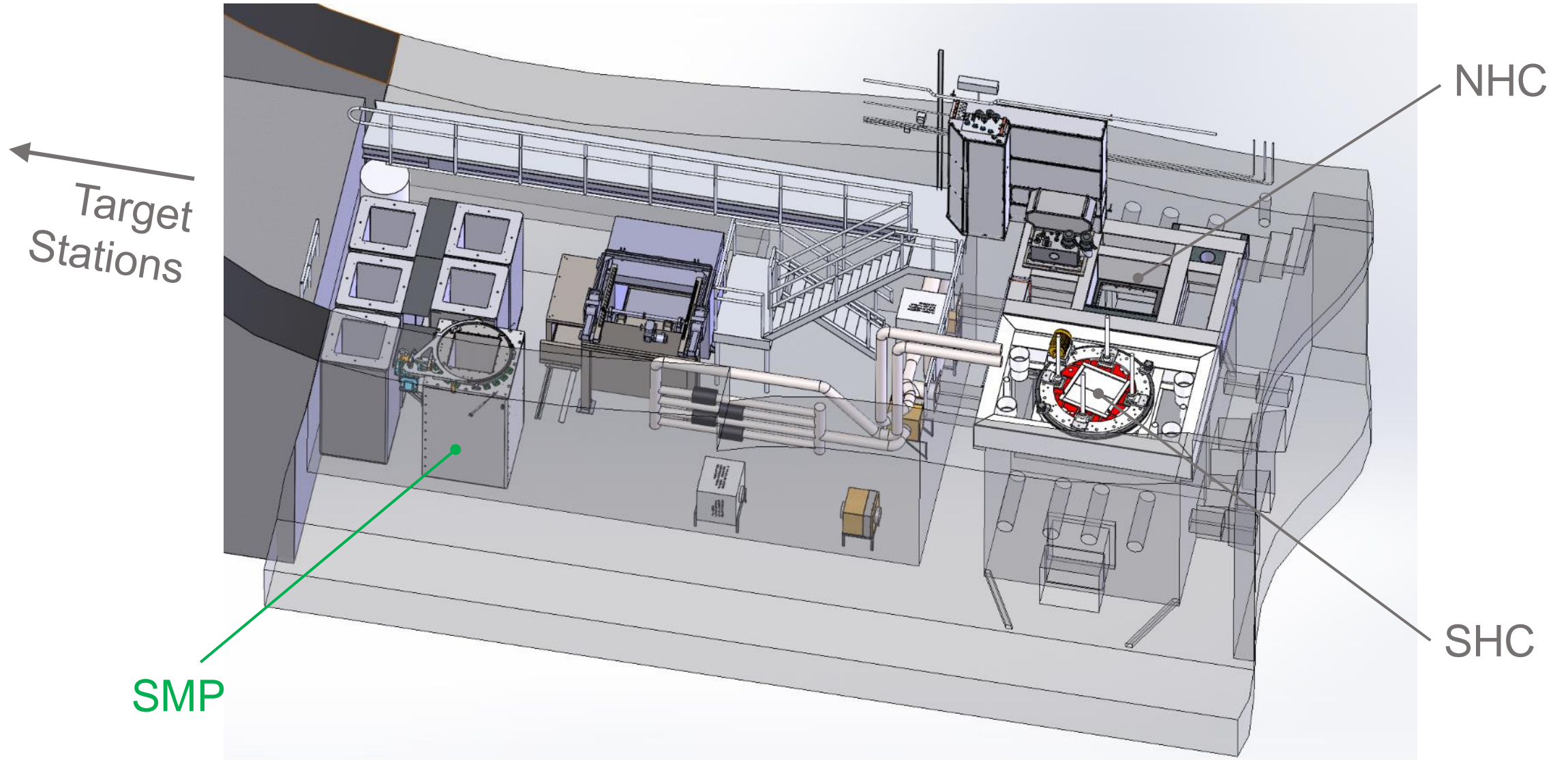

ISAC Waste Target Process – Module Access in Hot Cell

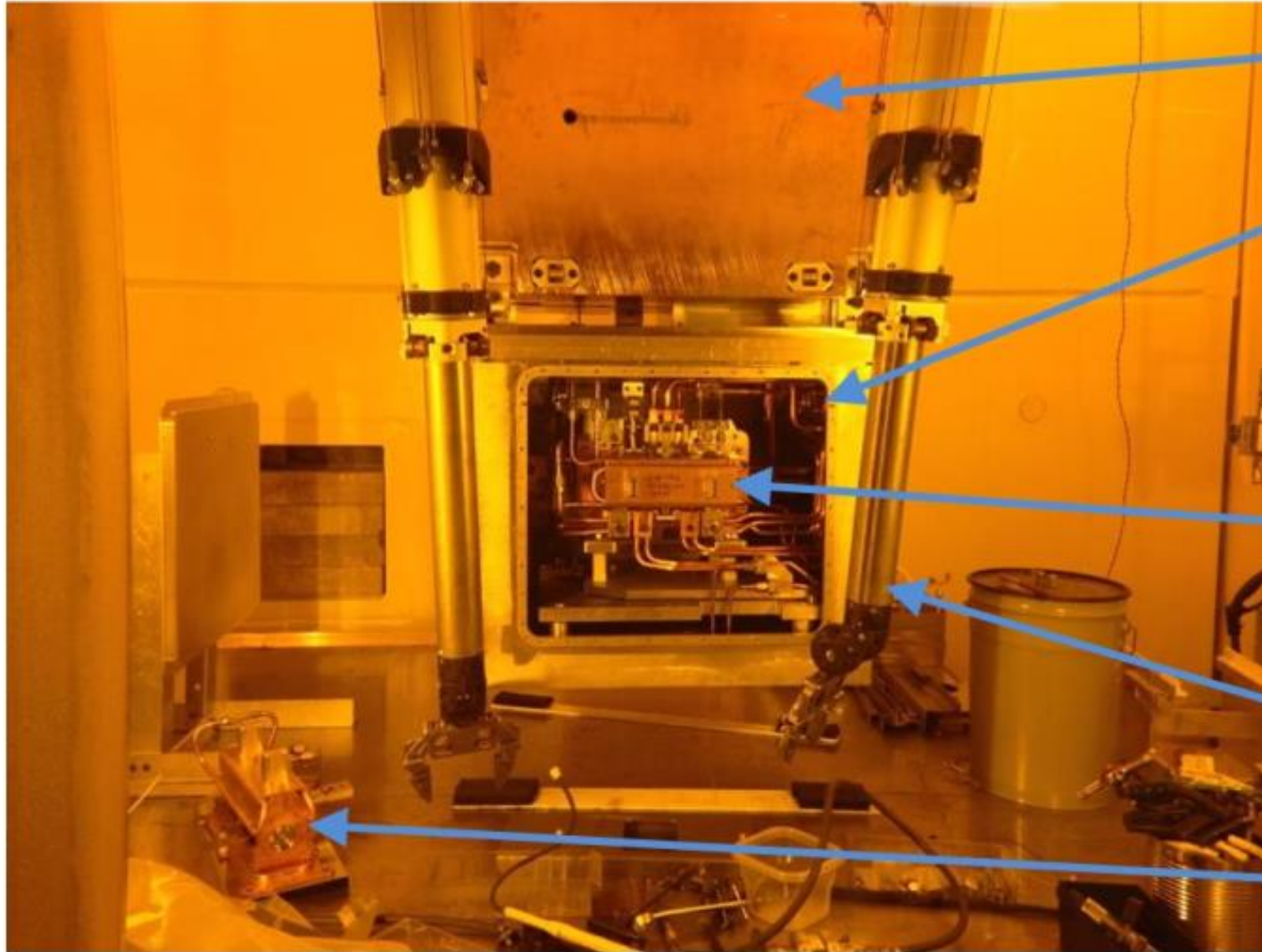

Target module shield plug

Target module containment box (open to expose target assembly)

New target assembly installed on target module

Telemanipulators

Expired target assembly removed

ISAC Waste Target Process – Target Packaging

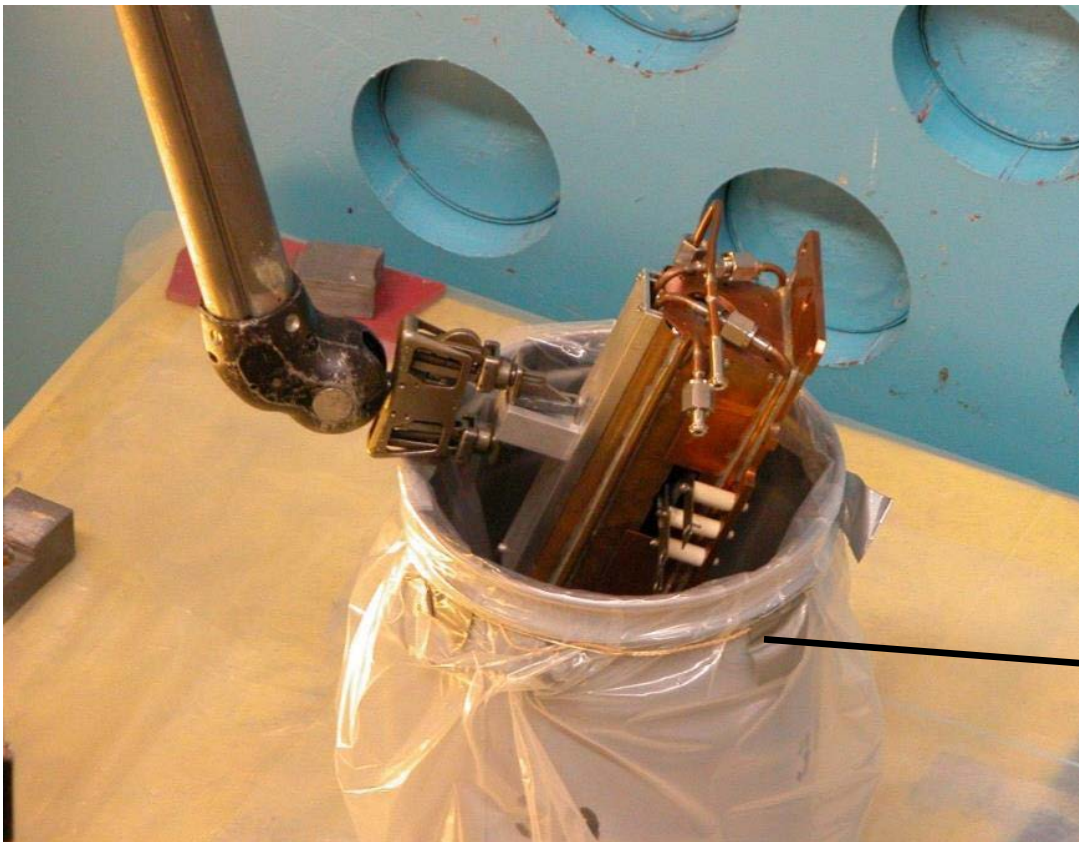

Target loaded into 5-gallon pail in the Hot Cell
After decay period, pail is loaded into Nordion F-308 shipping container (manual process!)



ISAC Spent Target Storage Vault



Decay storage vault door in open position

Spent target in 5-gallon pail, installed in decay storage vault drawer

Decay storage drawer (single drawer selected and pulled out with door)

ISAC Spent Target Pail Remote Crane Transport

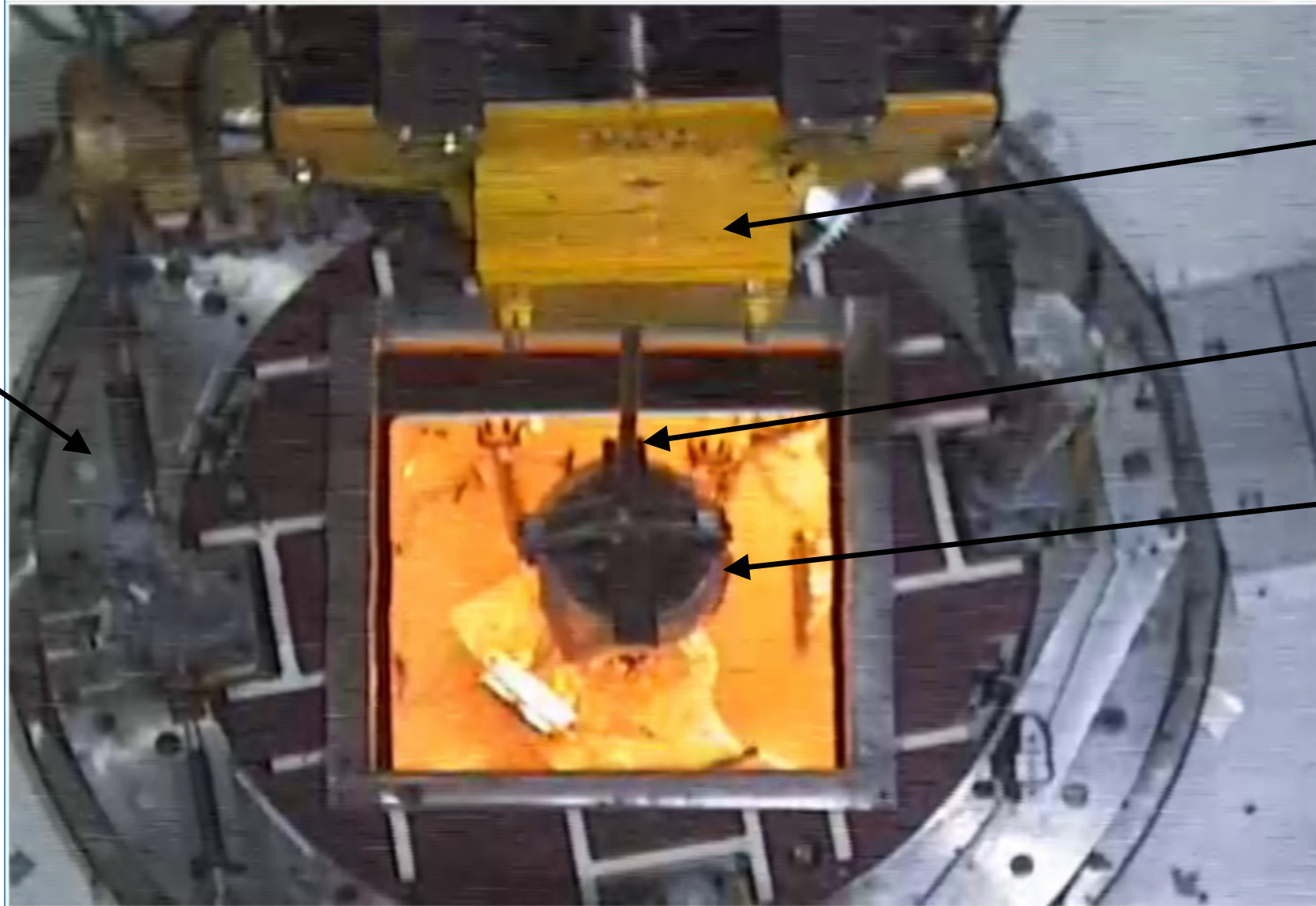

South Hot Cell
Turntable
Assembly

Remote Crane
Load Block

Pail lifting
tool

Spent target
in 5 gallon
pail

ISAC Spent Target Pail Remote Crane Transport

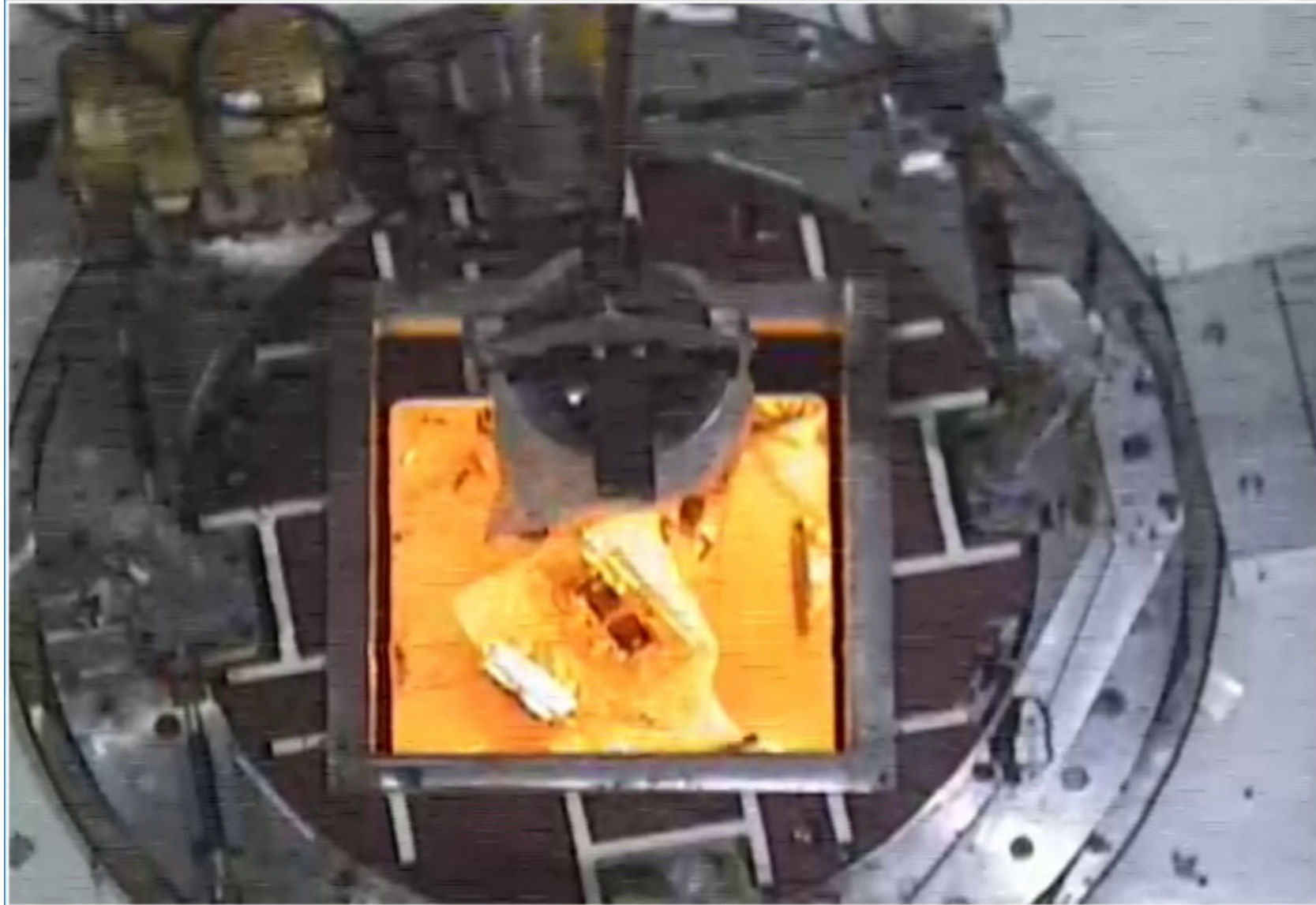

ISAC Spent Target Pail Remote Crane Transport



ISAC Spent Target Pail Remote Crane Transport



ISAC Spent Target Pail Remote Crane Transport



ISAC Spent Target Pail Remote Crane Transport



ISAC Spent Target Pail Remote Crane Transport

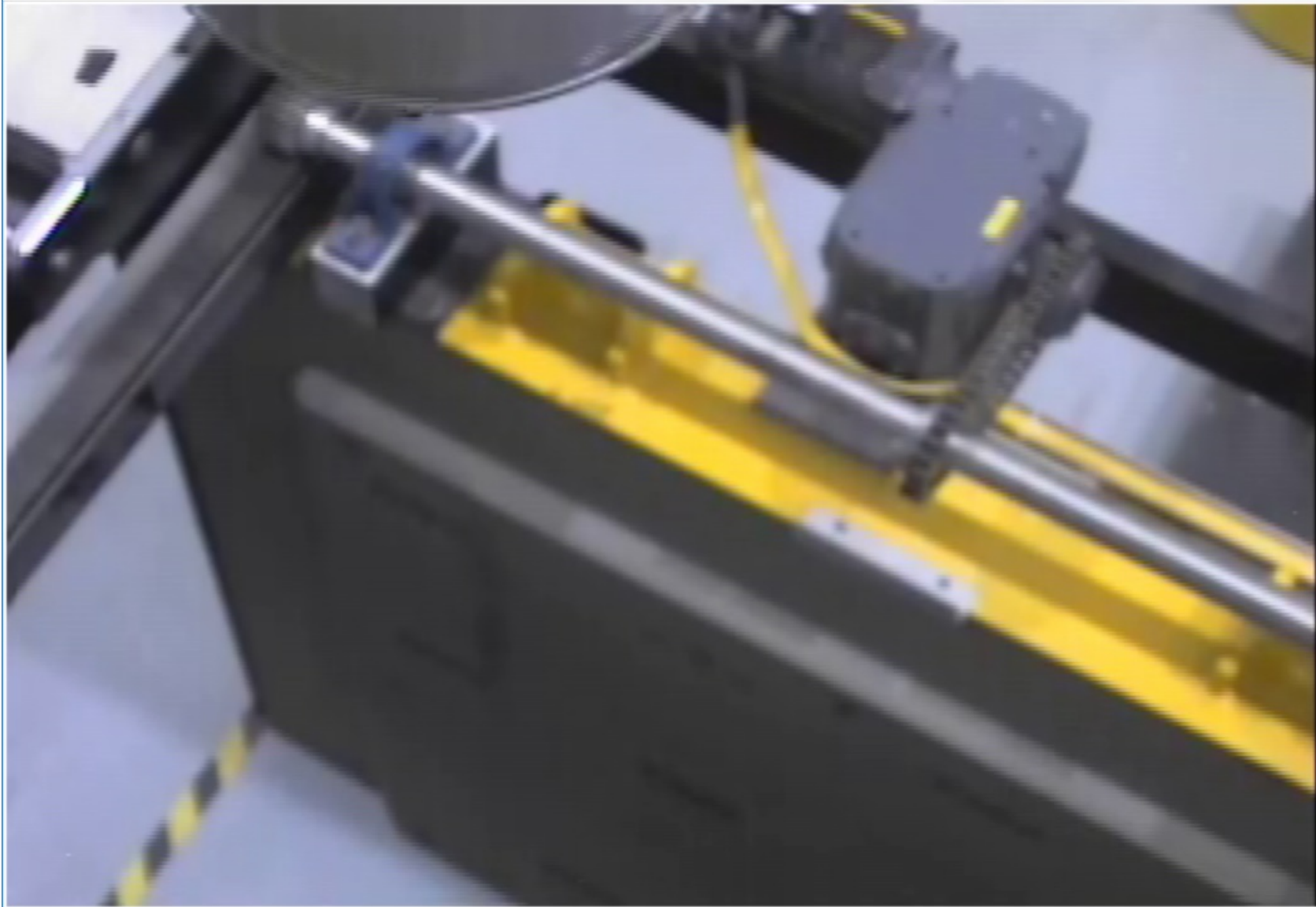

ISAC Spent Target Pail Remote Crane Transport

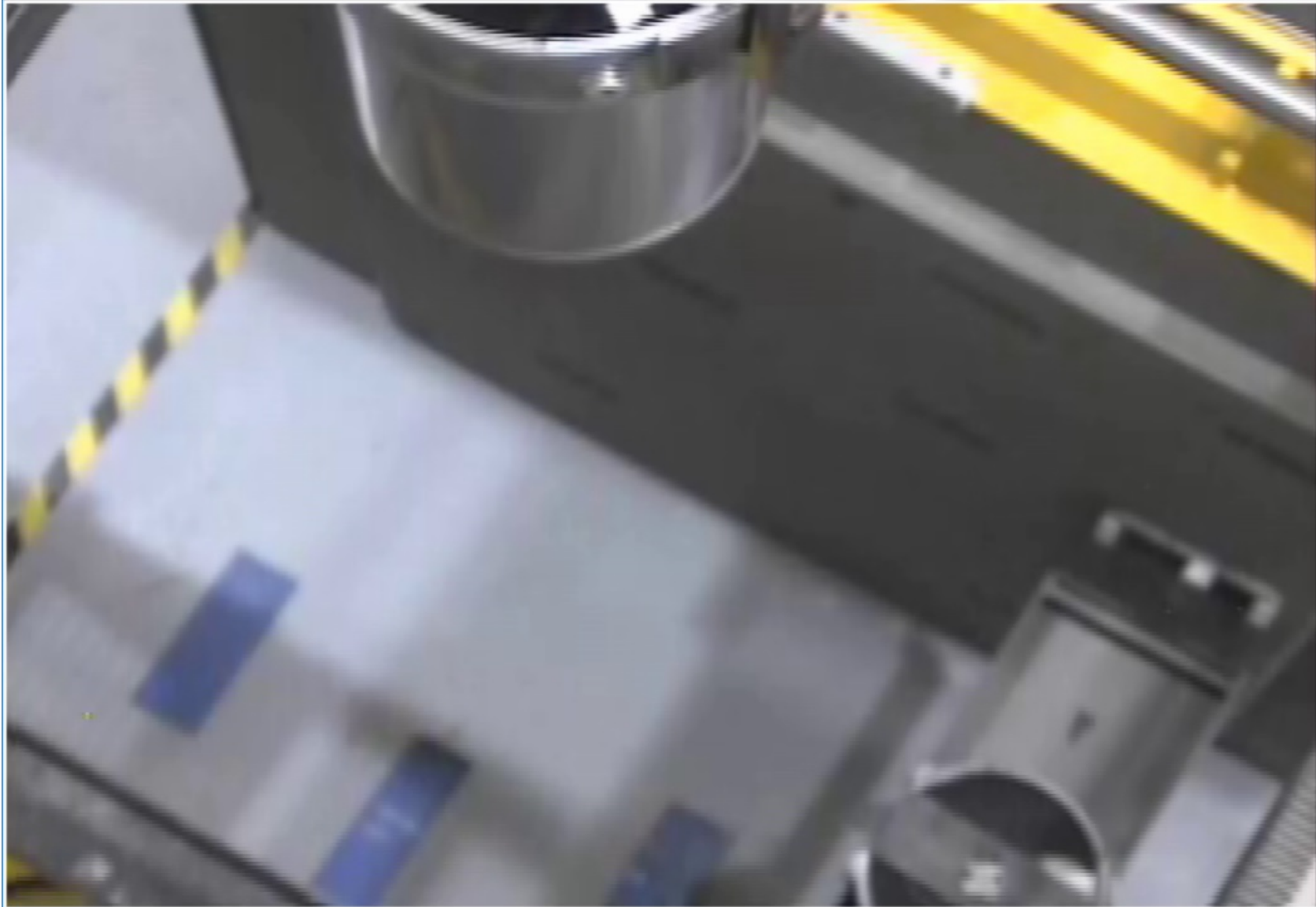

ISAC Spent Target Pail Remote Crane Transport

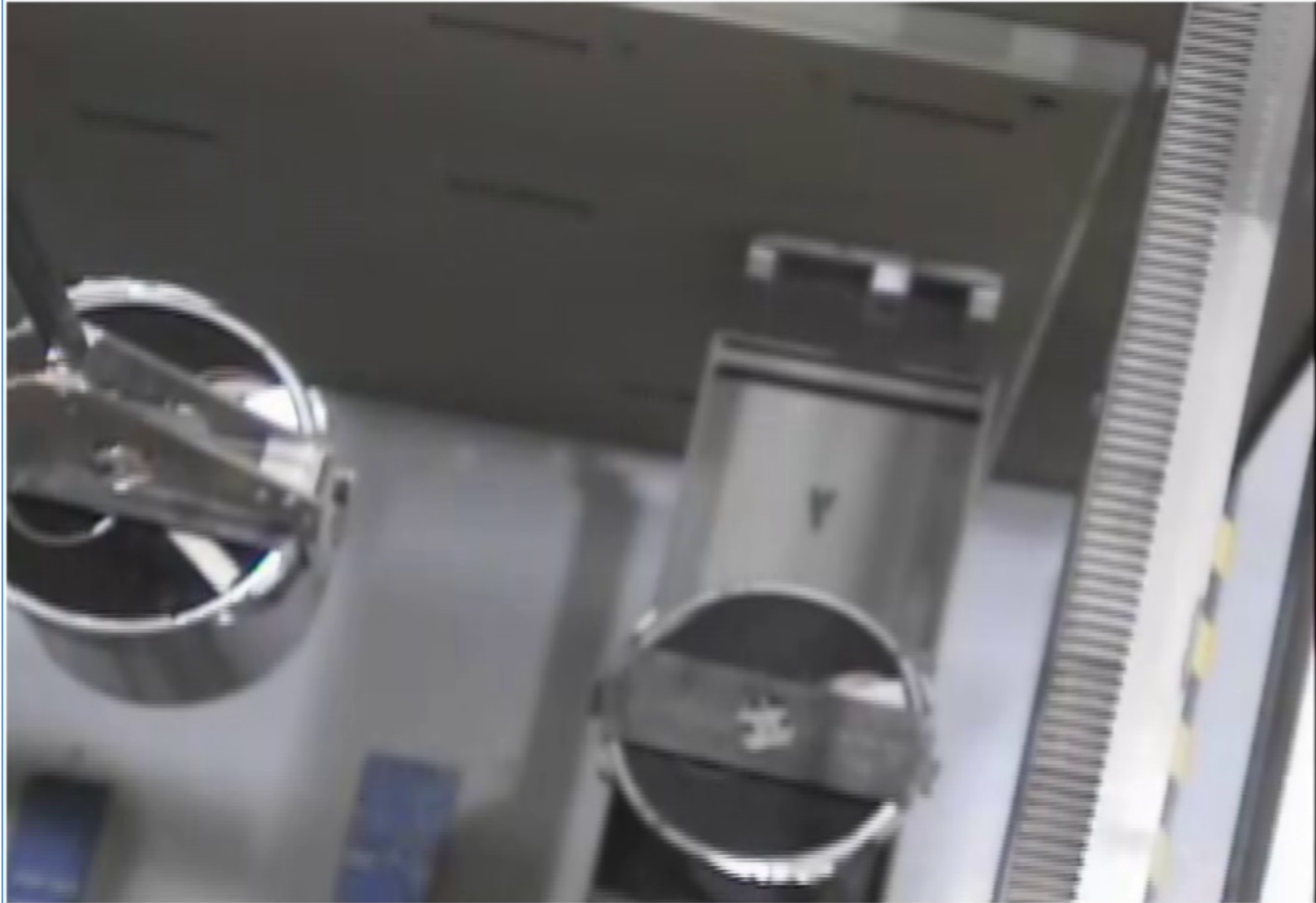

ISAC Spent Target Pail Remote Crane Transport

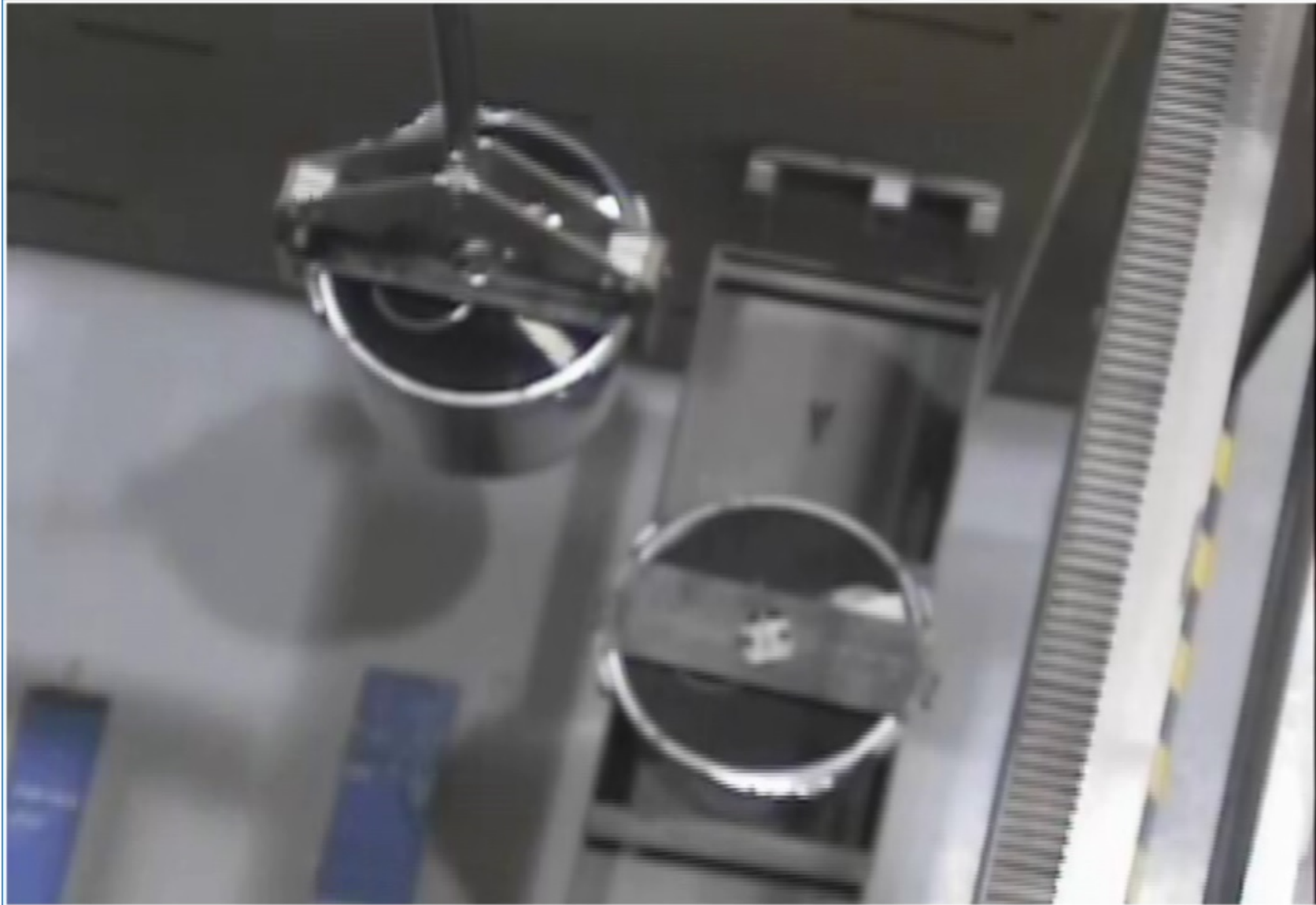

ISAC Spent Target Pail Remote Crane Transport

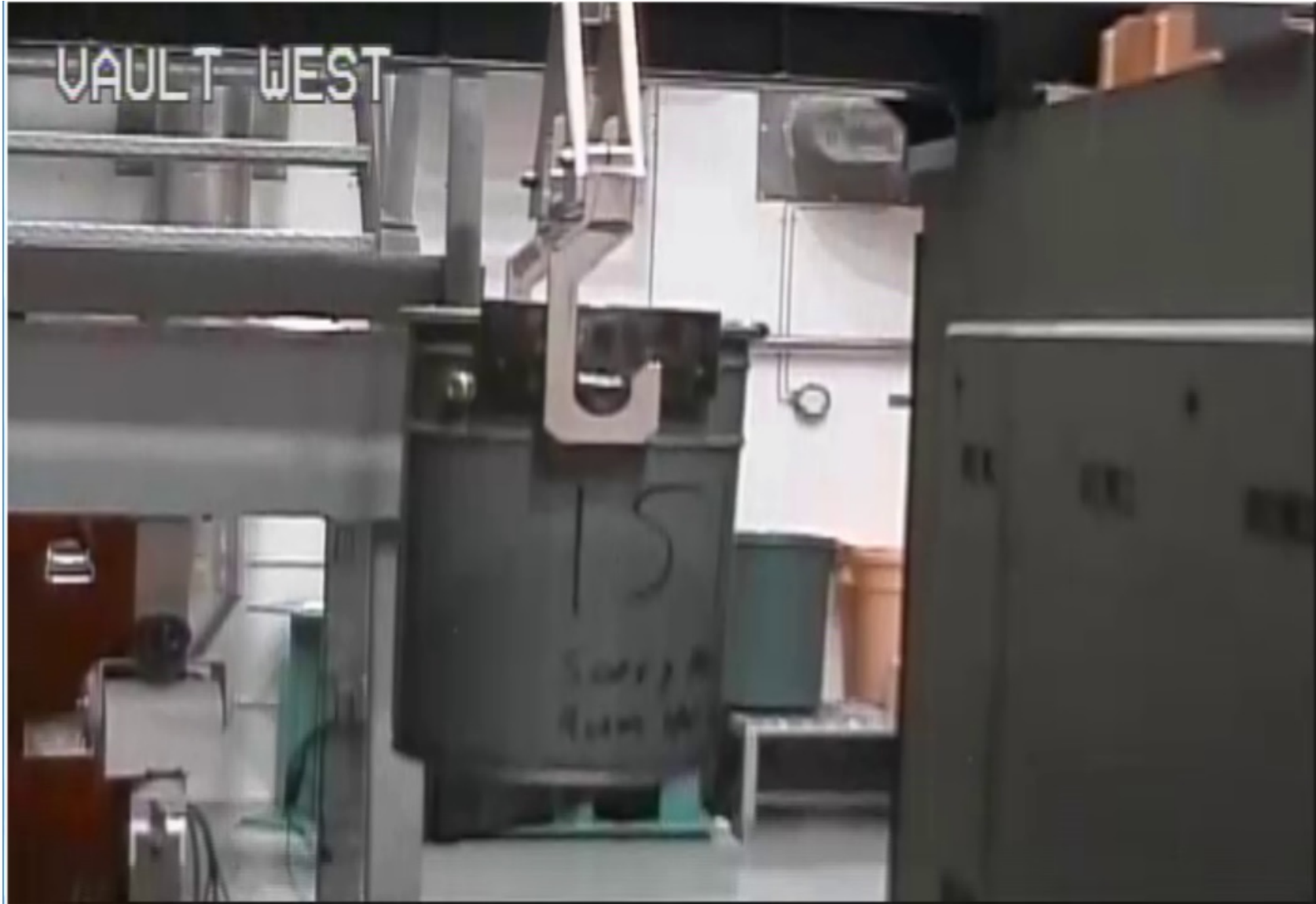

ISAC Spent Target Pail Remote Crane Transport



ISAC Spent Target Pail Remote Crane Transport



ISAC Spent Target Pail Remote Crane Transport

Δt :
1 to 2 hours
(Hot Cell to
Vault)

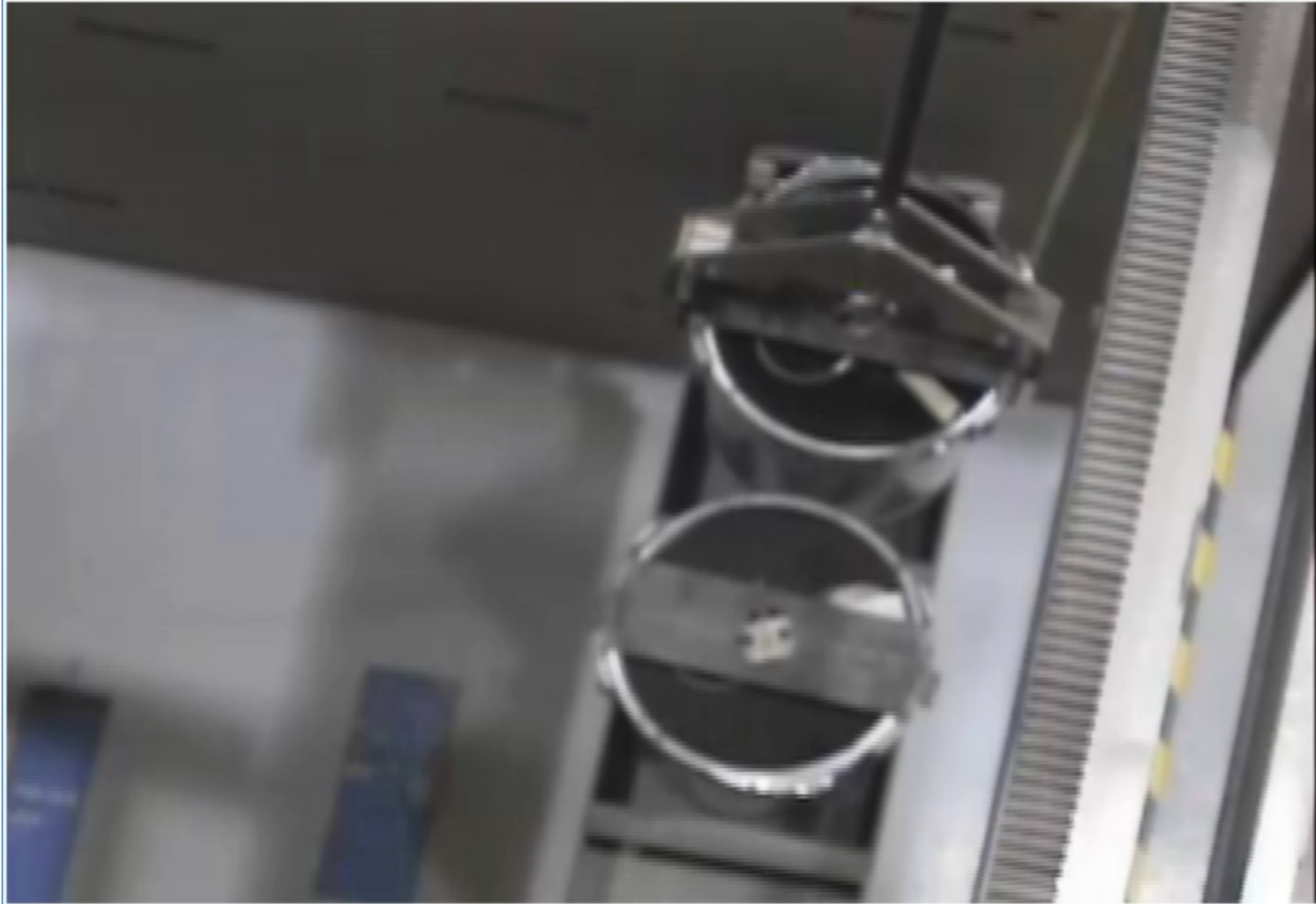

Remote Handling – Future Developments at TRIUMF

- Goal: crane-transportable system using fly-by-wire remote manipulators to perform routine dose jobs in multiple areas
- Prototype may be developed for ISAC waste flask loading

45

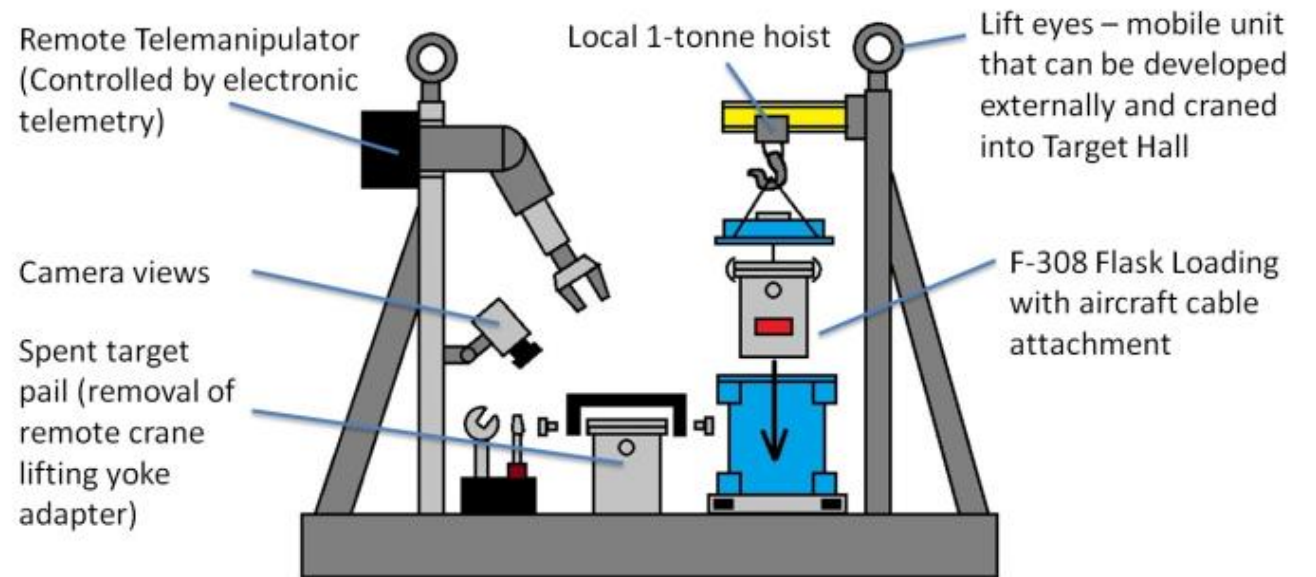

ARIEL Target Hall – Key Project Deliverables

- **Remote Handling Crane**
- **Hot Cell 1 Facility (ROBATEL INDUSTRIES, France)**
- **Target Hall Shielding Layout**
 - voids, services, materials, FLUKA simulations, engineering configuration
- **Target Transfer System**
 - target station -> decay storage vault -> hot cell
- **Target Station & RIB Beamline Support Structure**
- **Module Storage**
- **Module Storage Pit**

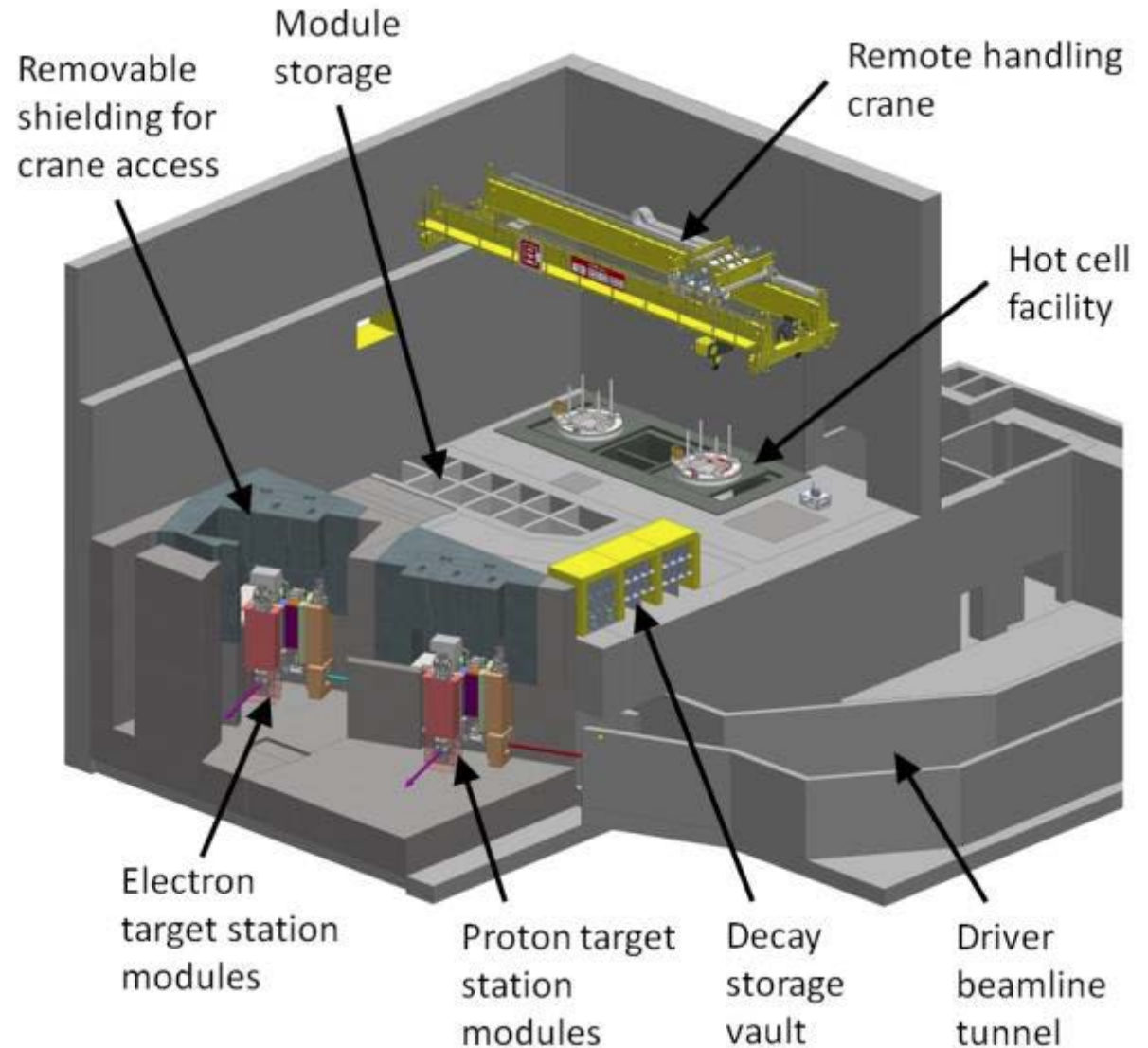

ARIEL Target Hall Crane – Installation 2015



ARIEL Target Hall Crane – Load Test Aug 2015



ARIEL Target Hall Crane – Remote Controls



Primary Functionality

- 20 MT remote main hoist
- 6.8 MT North and South aux hoists (not remote)
- Double drive motors
- Double hoist drums and hoist motors
- “True” vertical lift
- Hydraulic jacks to lift seized drive wheel (bridge and trolley)
- Controls and electronics outside the target hall
- Motorized rotation below load block
- Bridge, trolley, hoist, and rotation position encoders

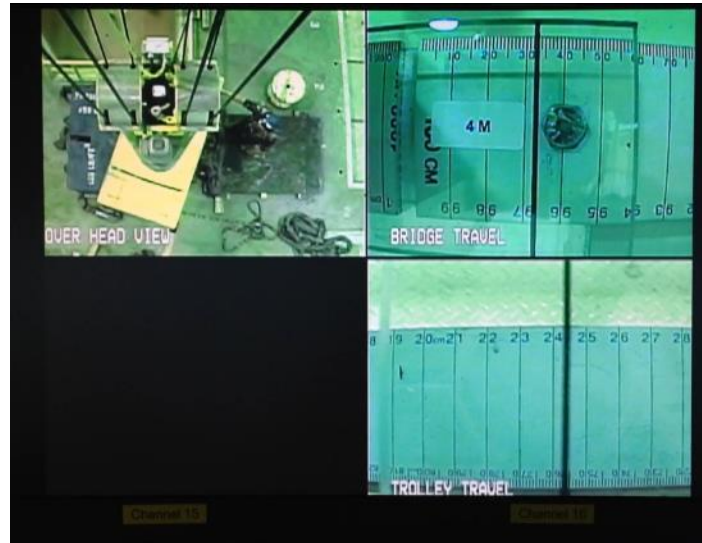

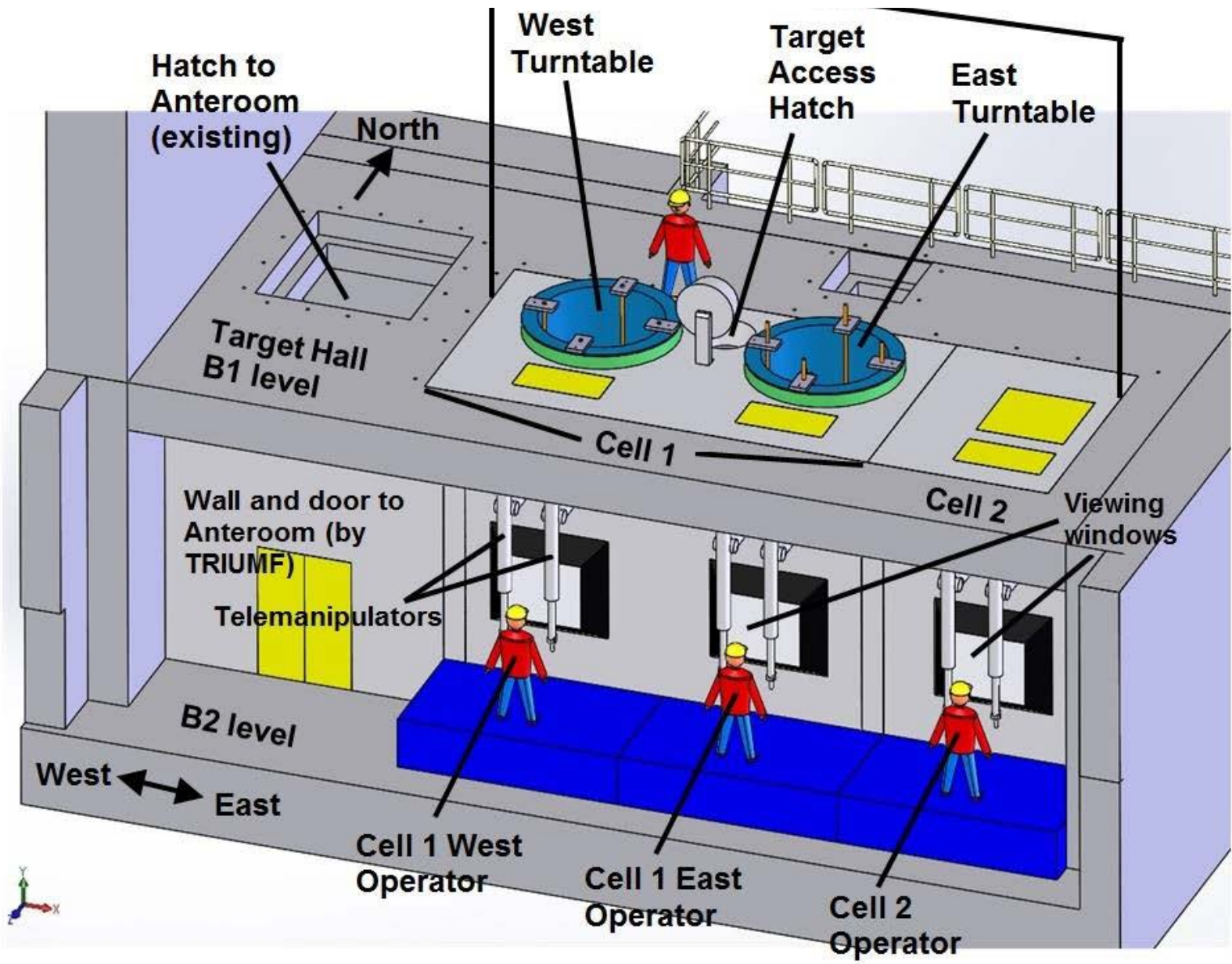

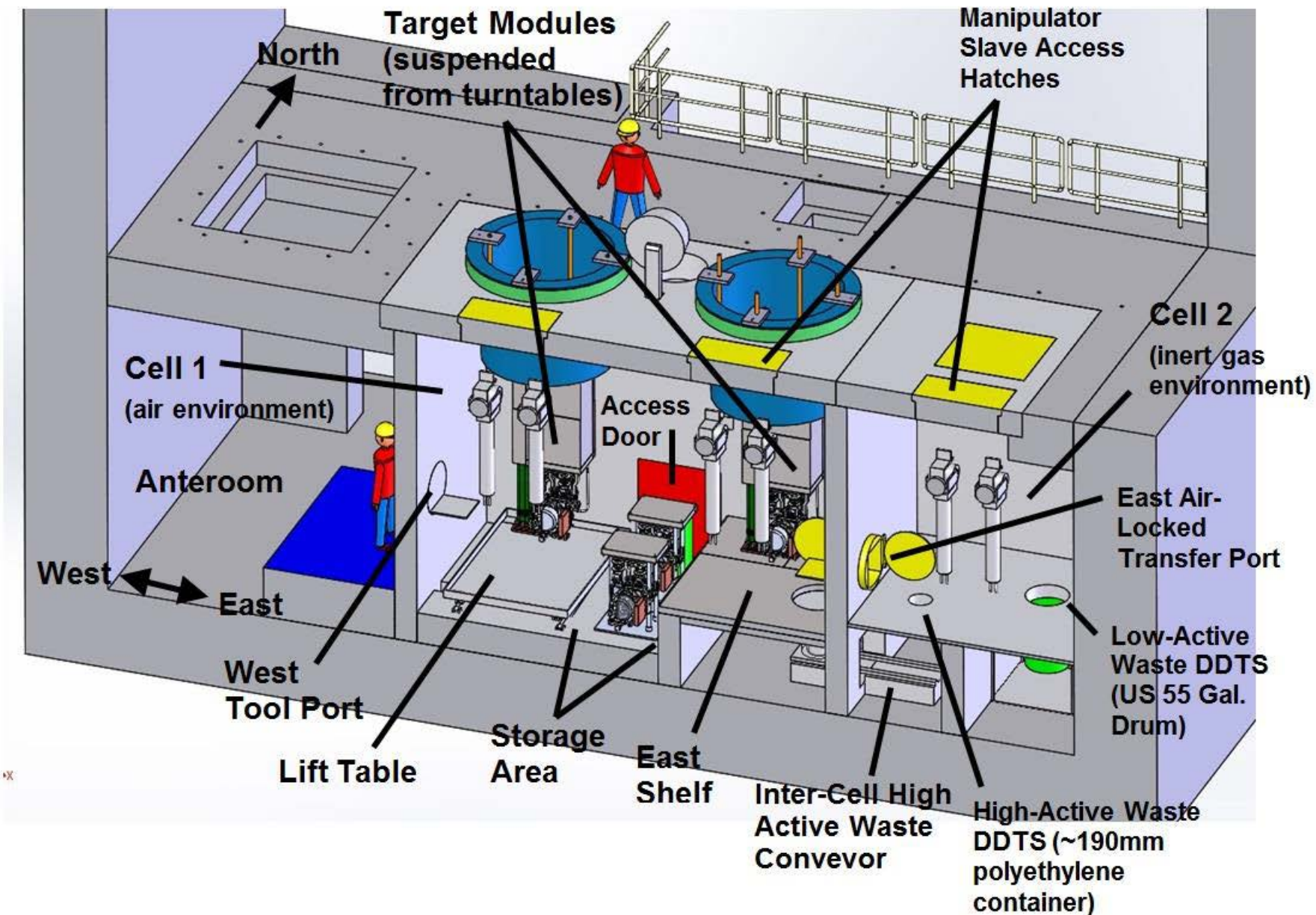

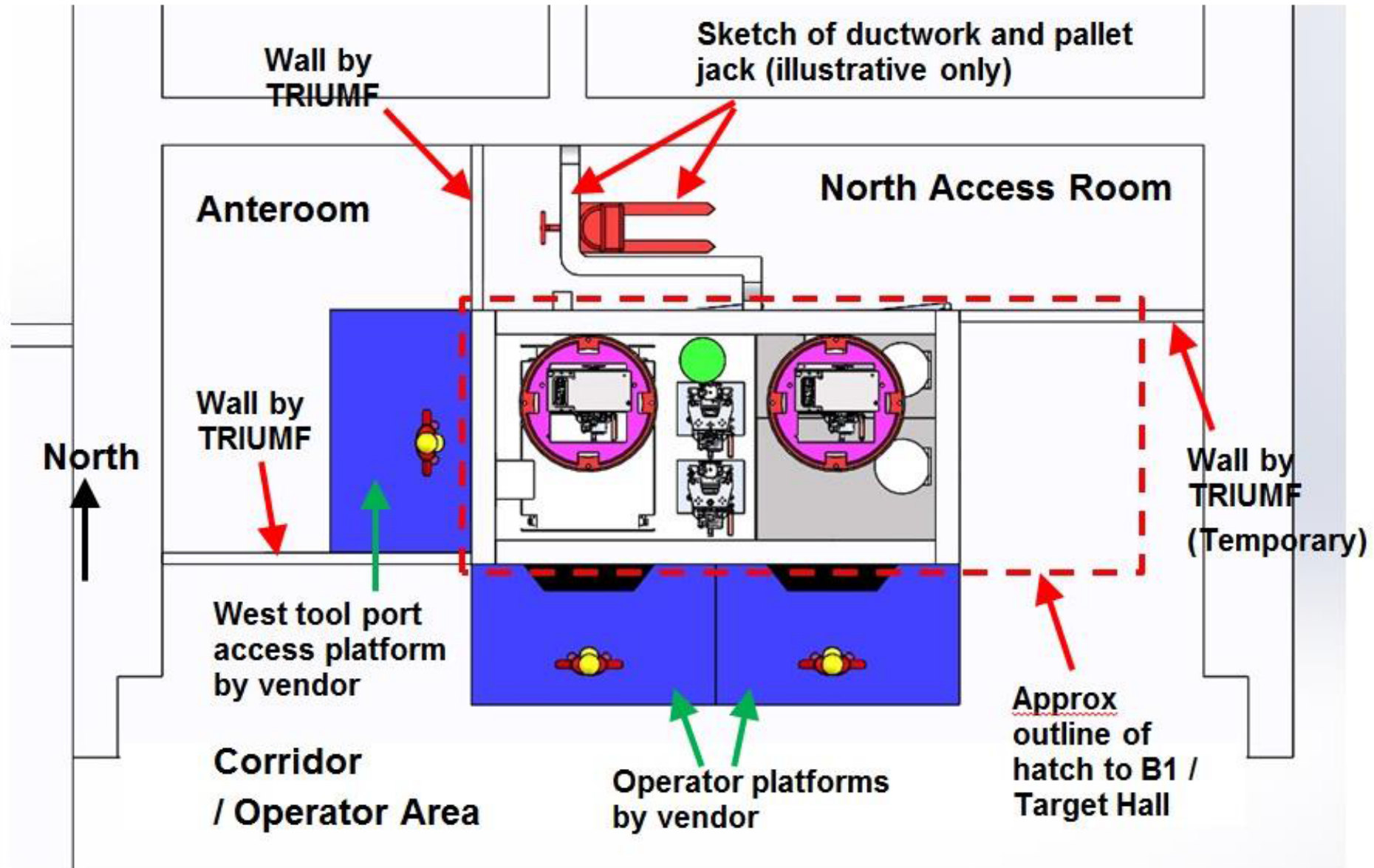

ARIEL Hot Cell 1 – Contract Scope

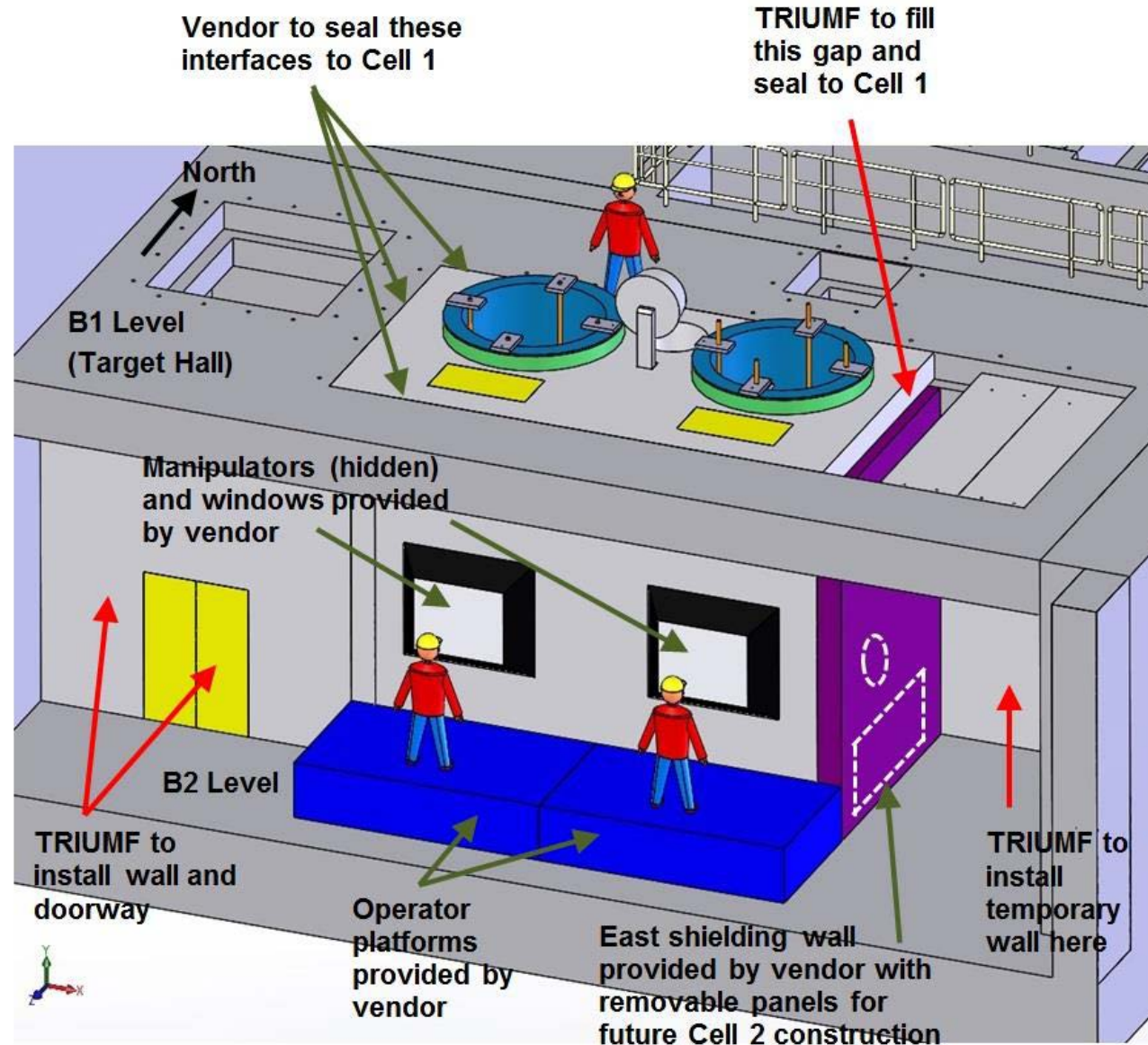

Hot Cell 1 – Design Images from ROBATEL

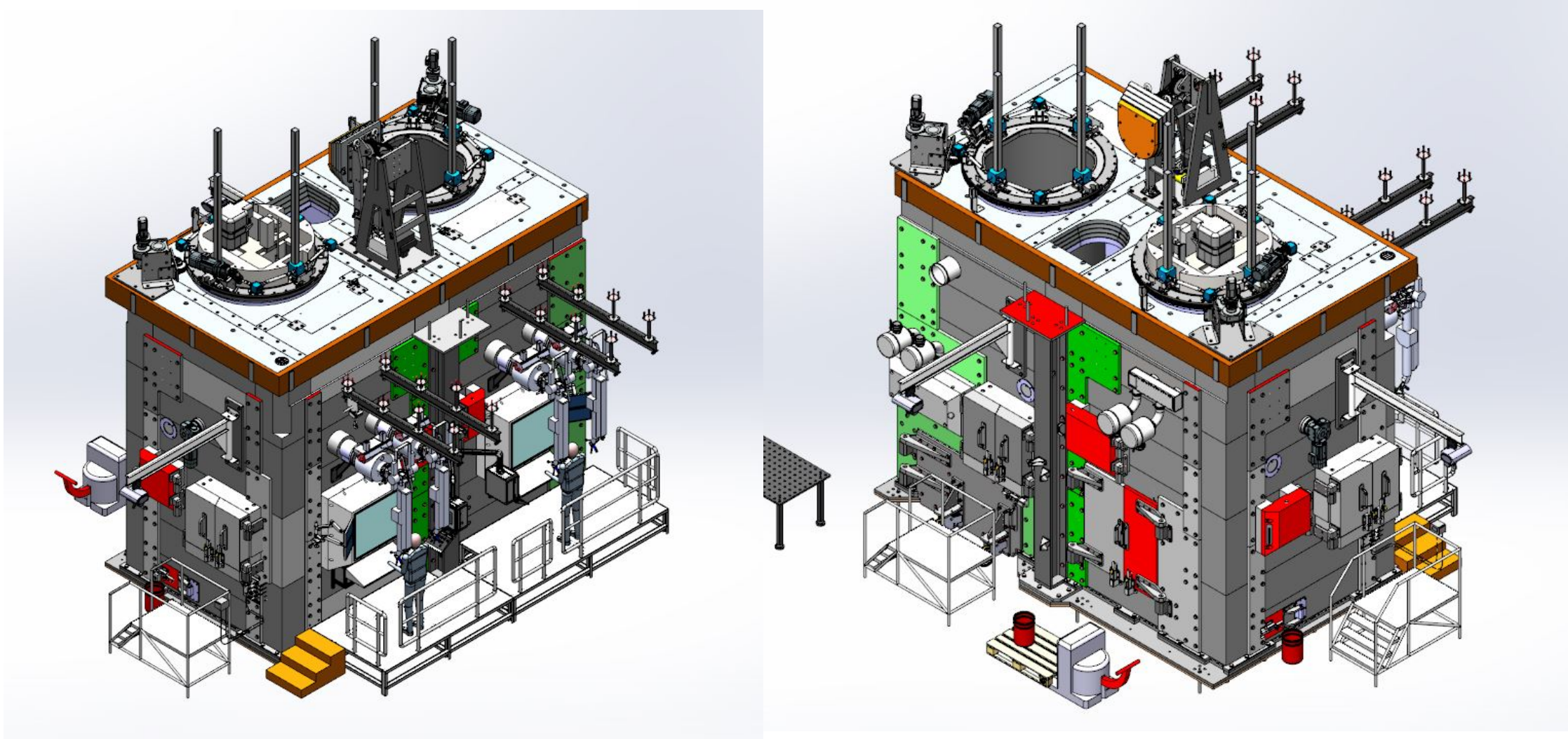

Hot Cell 1 – Design Images from ROBATEL

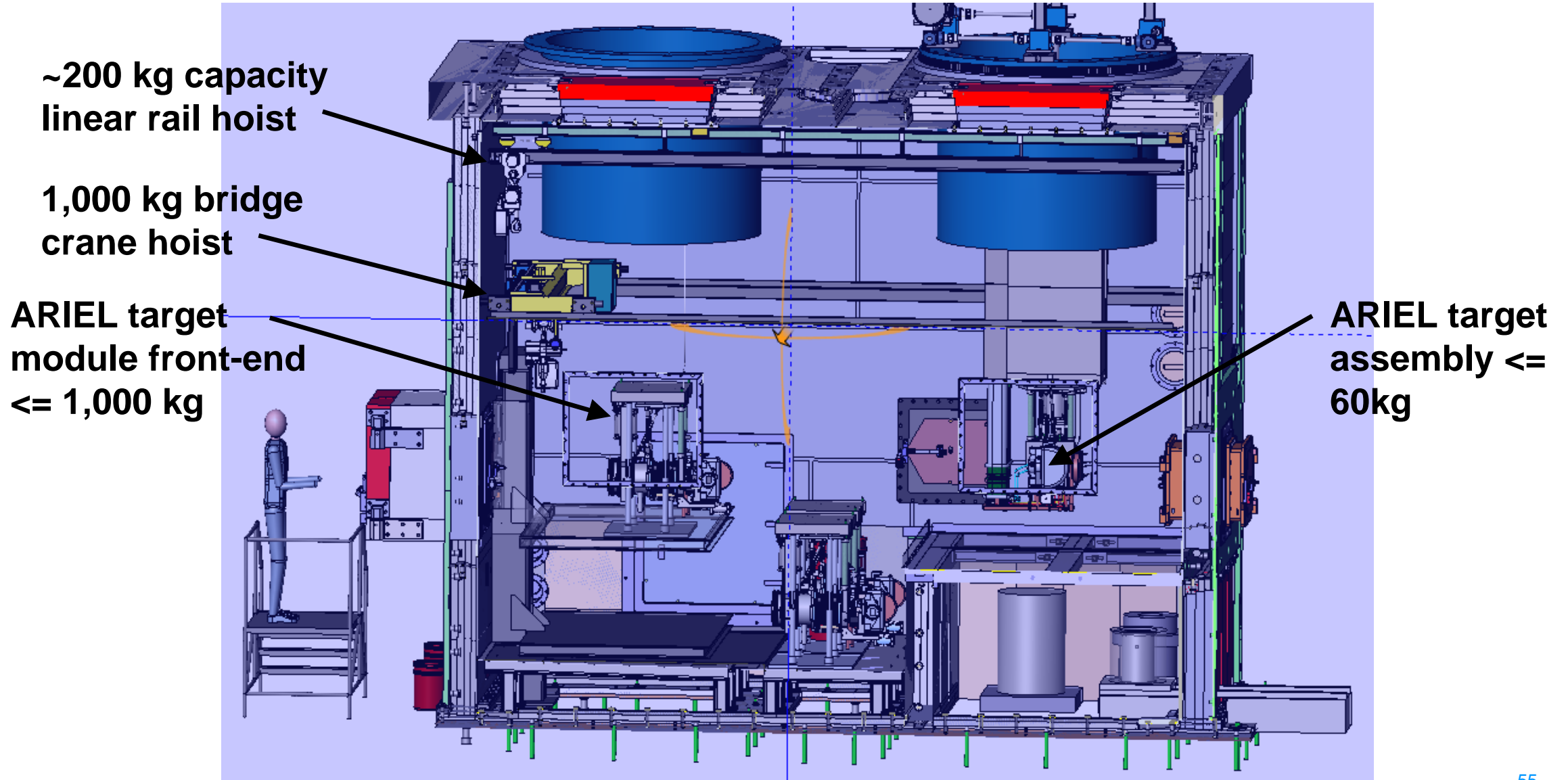

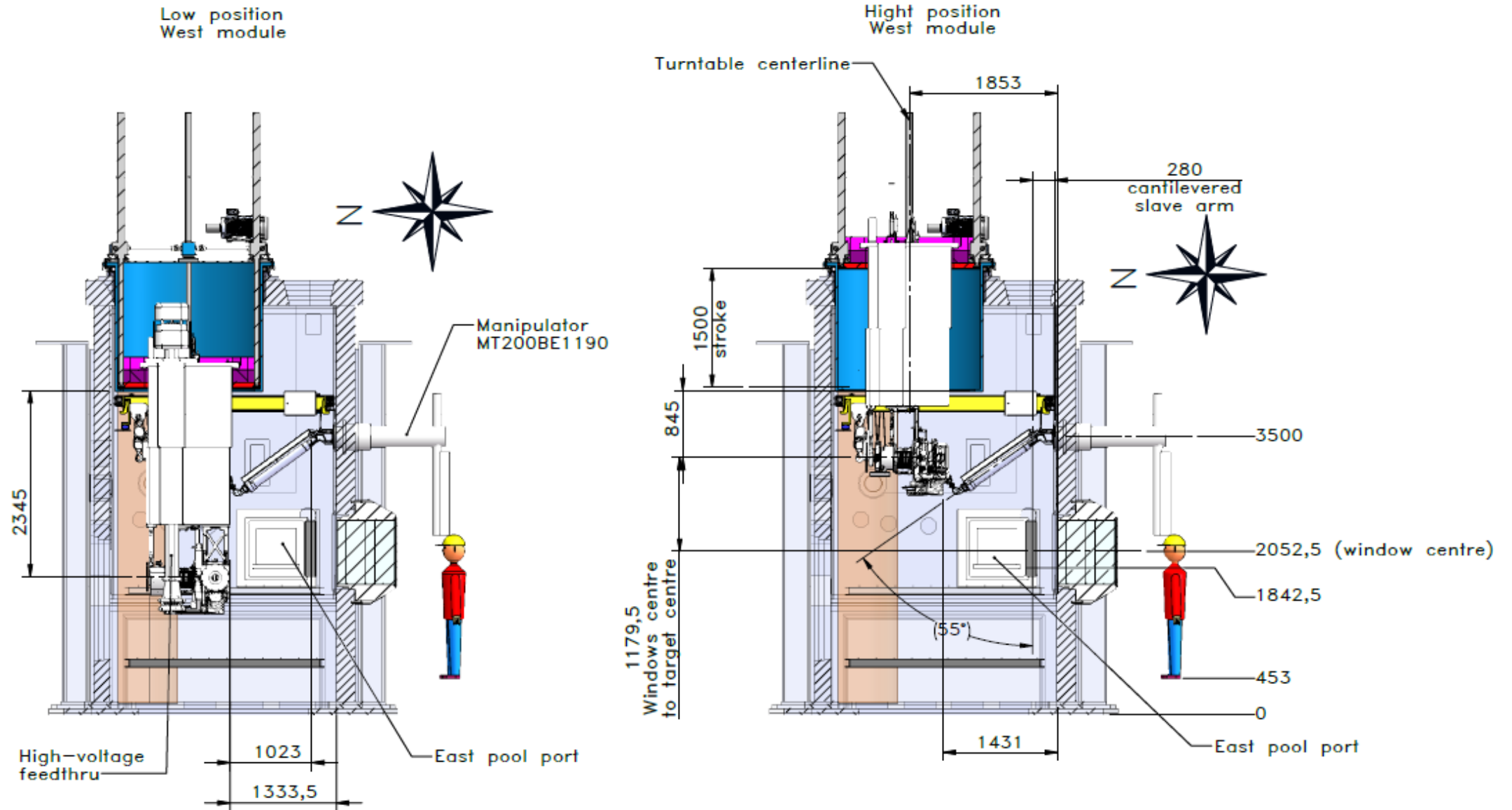

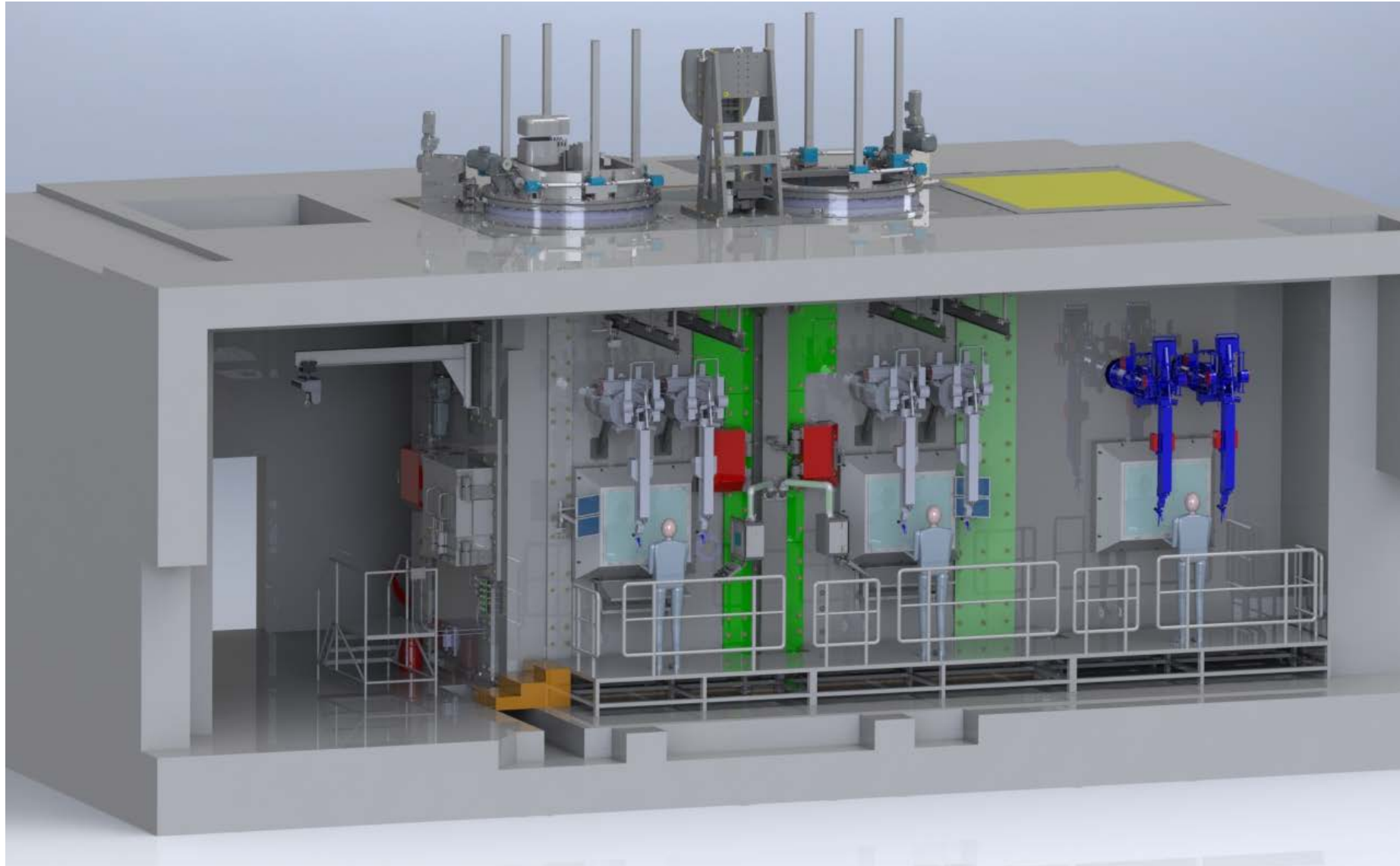

Transfer of a spent Target Assembly from Storage Vault to Cell 2 for processing

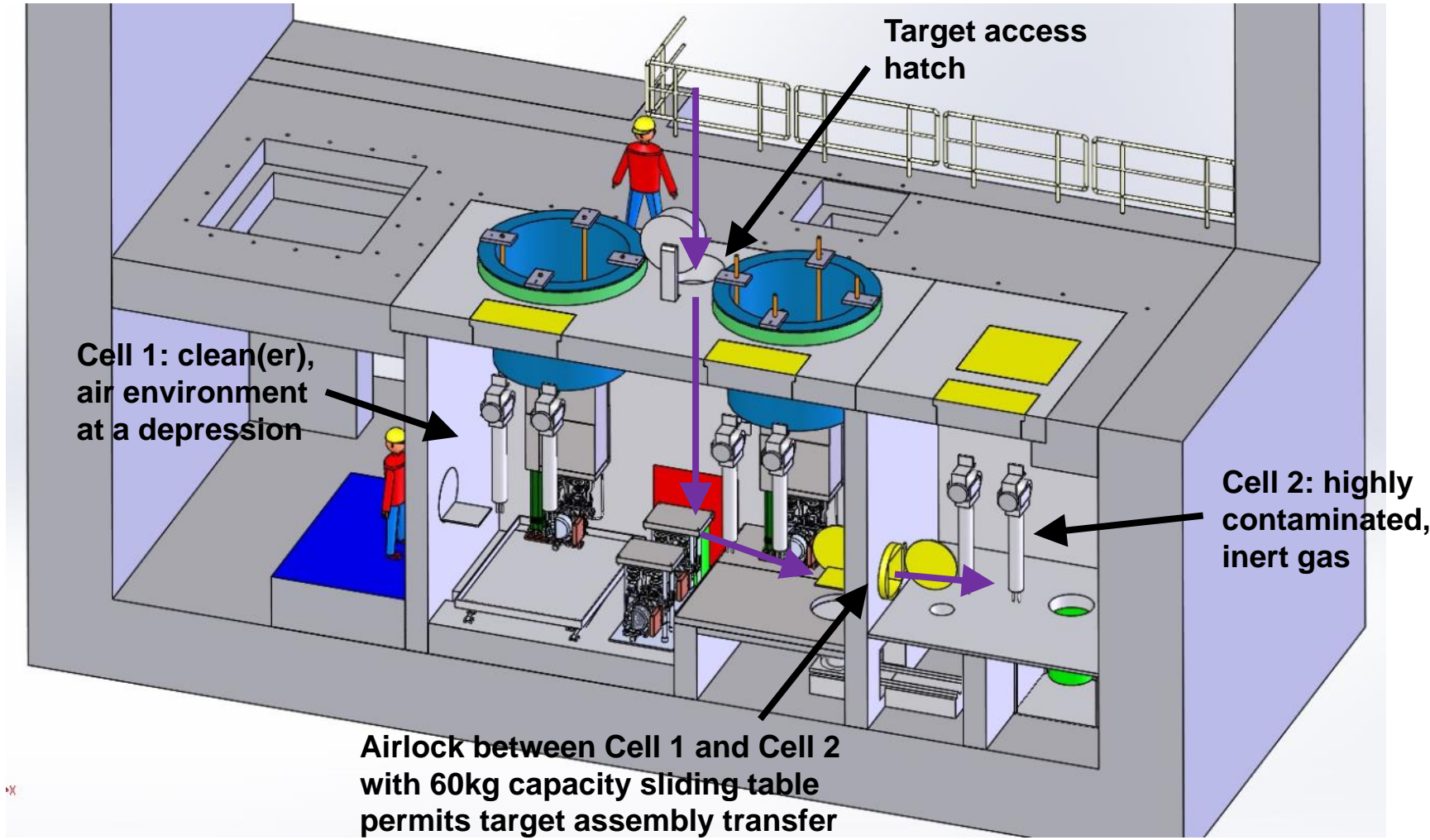

Cell 1: clean(er),
air environment
at a depression

Target access
hatch

Cell 2: highly
contaminated,
inert gas

Airlock between Cell 1 and Cell 2
with 60kg capacity sliding table
permits target assembly transfer
between cells

Waste Container / Shipping Flask Access

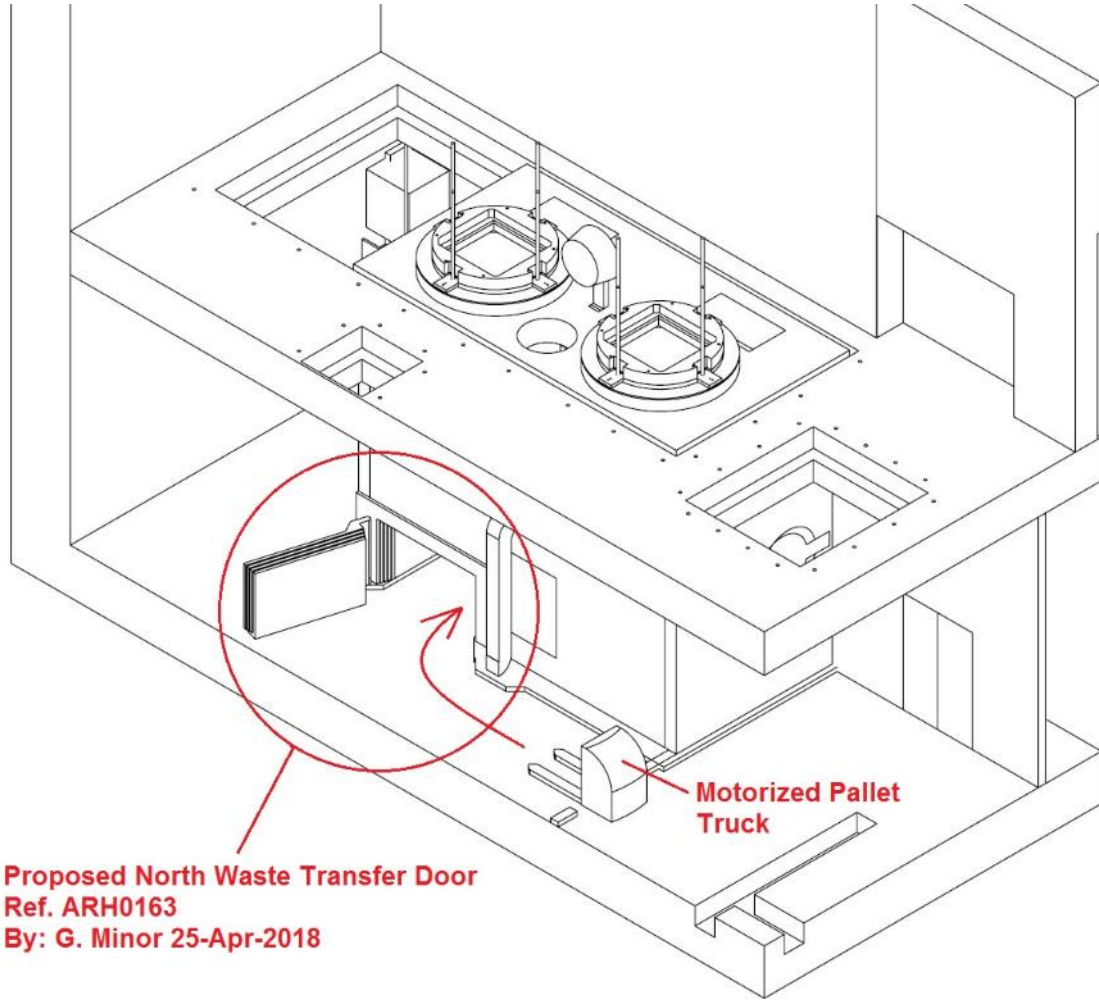

Proposed North Waste Transfer Door
 Ref. ARH0163
 By: G. Minor 25-Apr-2018

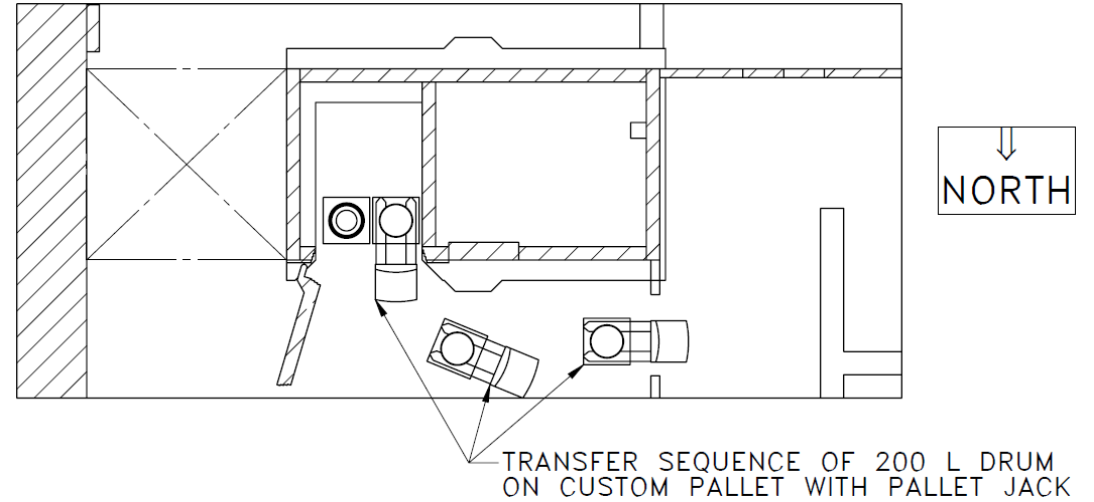

ARIEL Hot Cell - Waste Packaging Interfaces

2) F308 shipping flask opened and waste container inserted using telemanipulators and interior lifting equipment

Waste transfer door closed to maintain ventilation seal during this operation

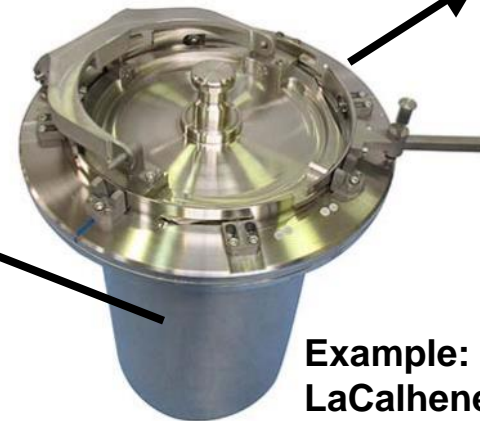
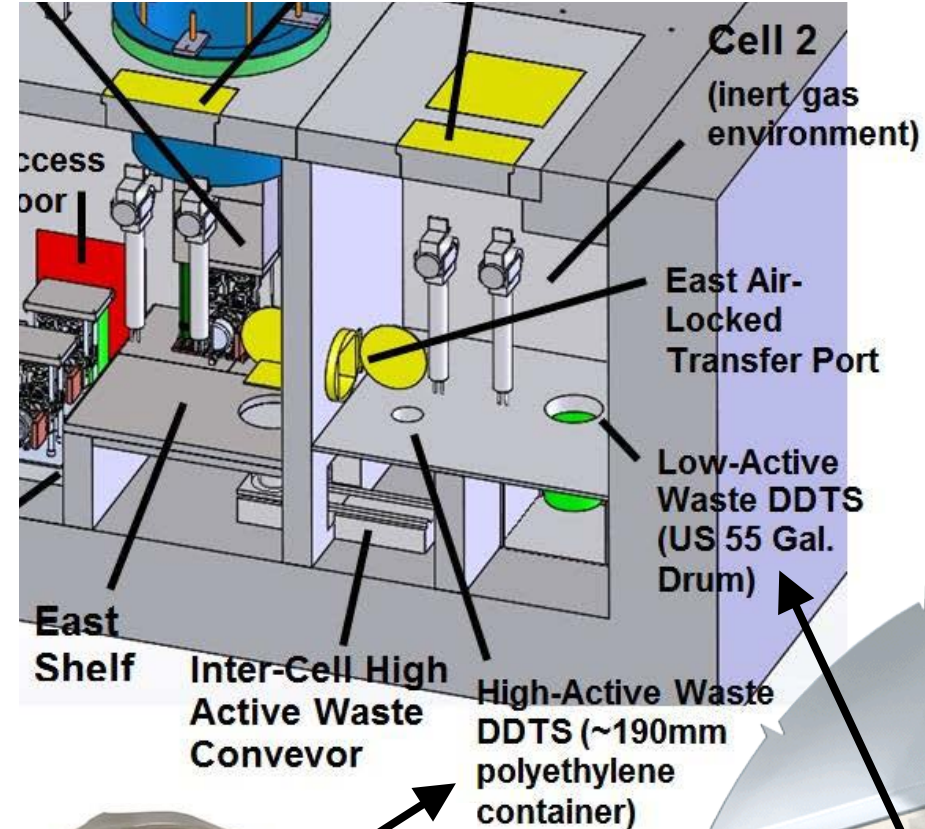
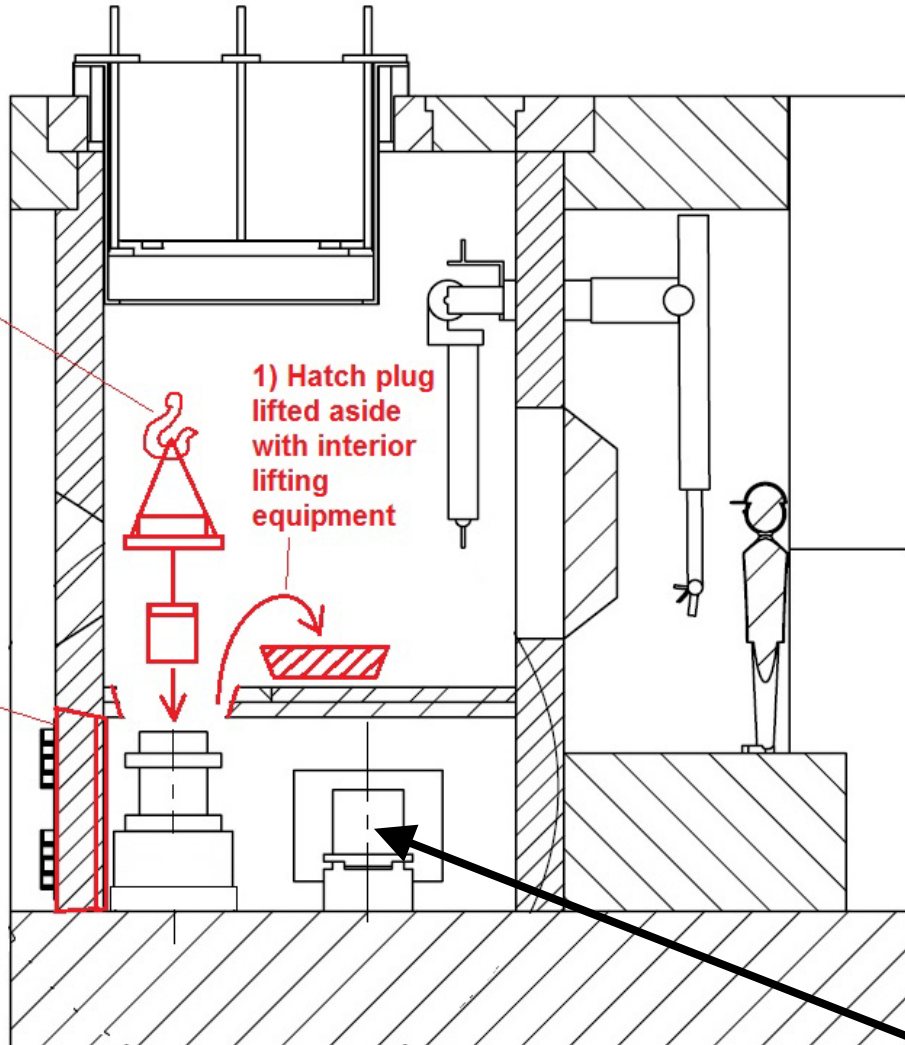

Example: CRL 55 Gallon Drum Dock

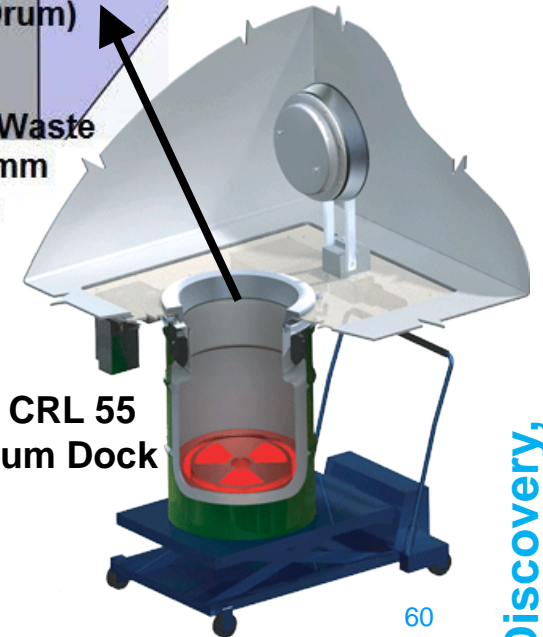

ARIEL Target Transfer System – Prototype Tests

Target Exchange Tool & Remote Handling Crane Development – Sept to Dec 2017 – Jason Kapalka

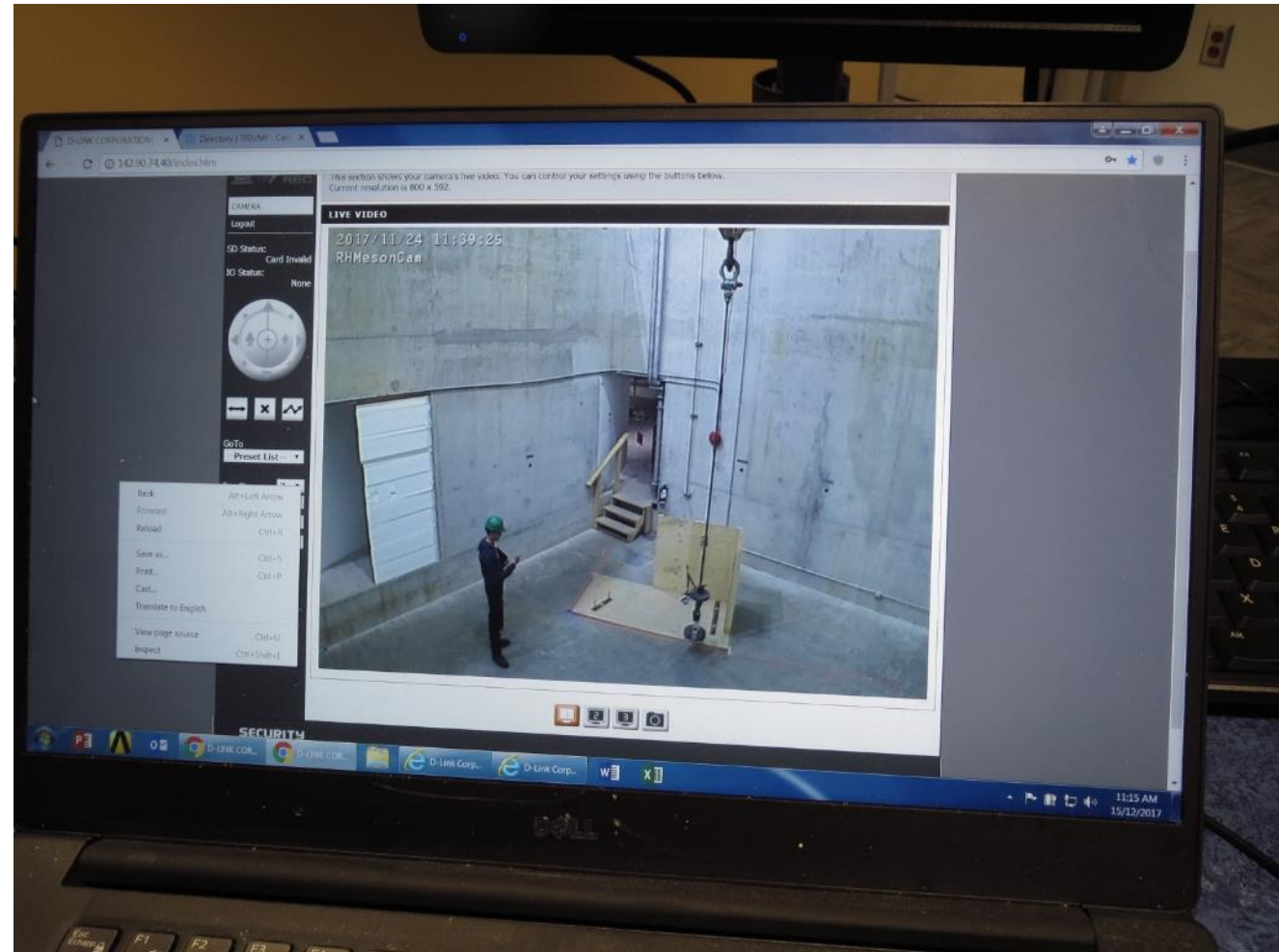
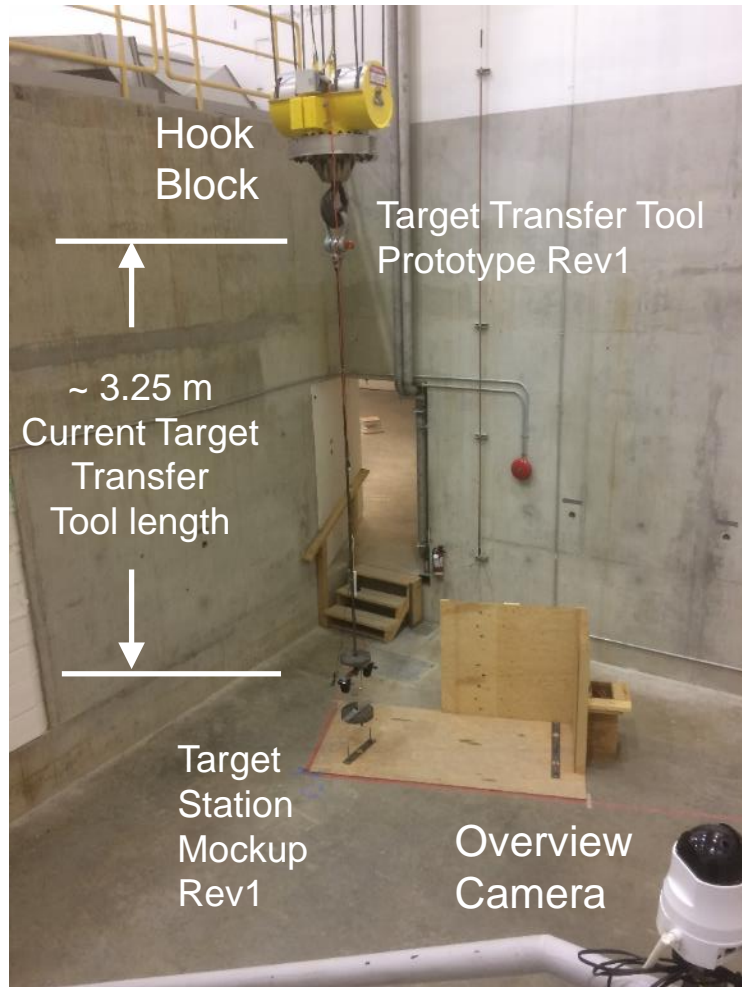

ARIEL Target Transfer System – Remote Pick and Place

Precedent for remote pick-and-place of ARIEL Target Assembly (60kg) using the target hall crane set by ISAC spent target handling

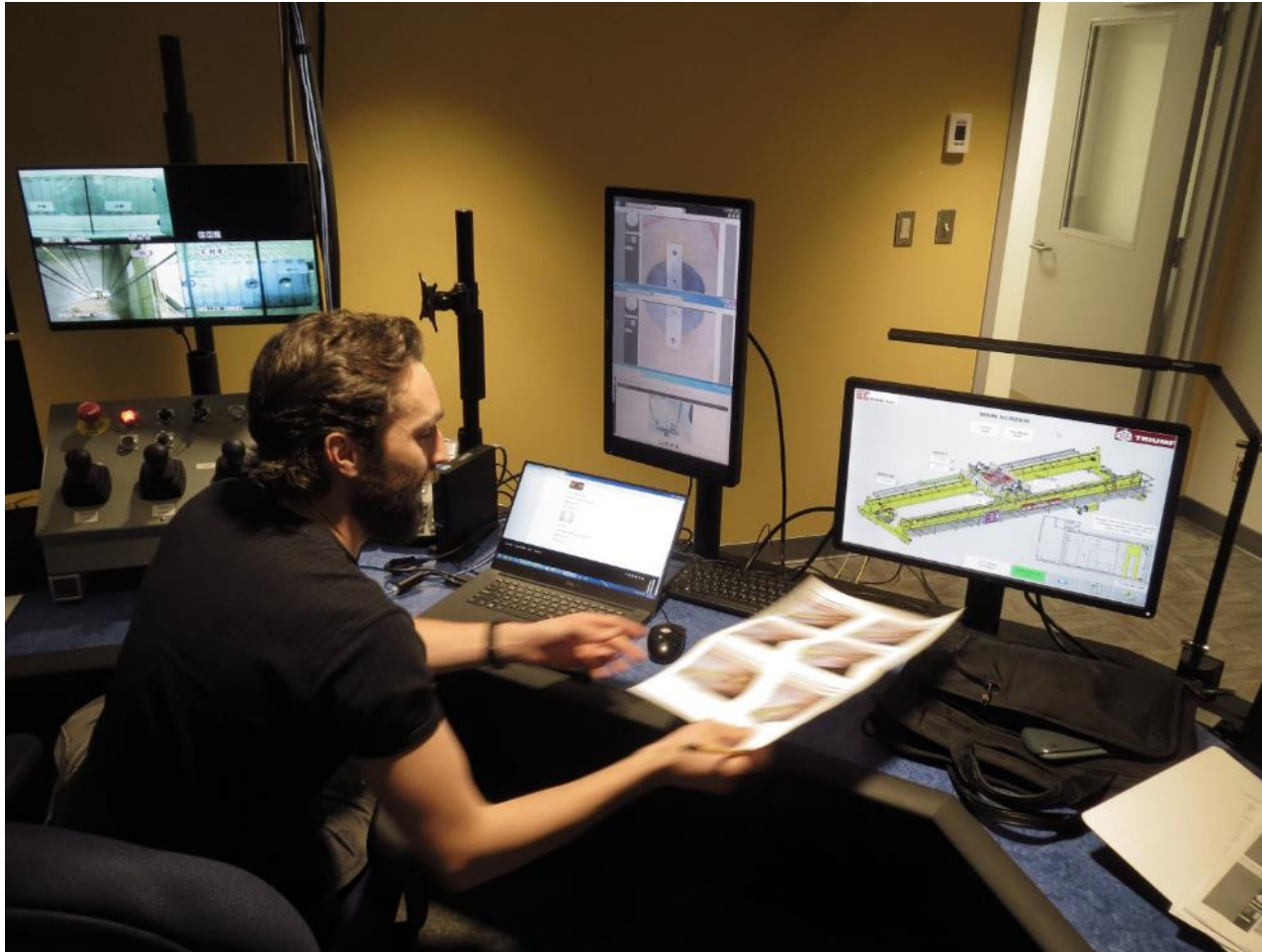

Successful remote pick-and-place of 30kg object via Remote Handling crane between 2 pinned locations with Target Transport Tool 15-Dec-2017

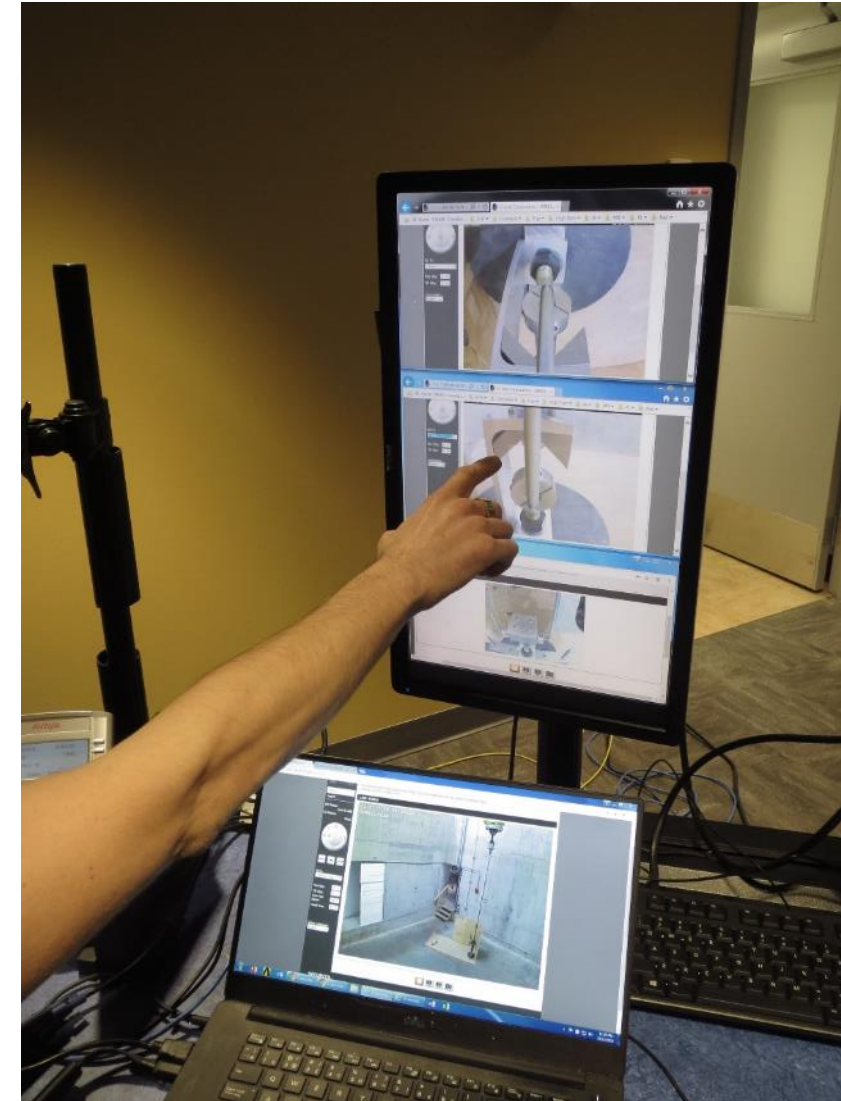

ARIEL Target Transfer System Second Iteration Test



Successful local pick-and-place of ISOLDE target vessel (much closer to ARIEL design) object via Remote Handling crane onto ISOLDE locating pin design – 16-March-2018

Acknowledgements – Thank You!

- Mike Gallop
- Chad Fisher
- Guy Stanford
- Clive Mark
- Travis Cave
- Don Jackson
- Jason Kapalka
- Isaac Earle
- Alex Gottberg
- Maico Dalla Valle
- Tom Lyth
- Kevin Chen
- Bill Paley
- Dan Rowbotham
- Keith Ng
- Allon Messenberg
- Alejandro Samper
- Nemanja Jovicic
- Yasmine Saboui
- Anders Mjøs
- Oliver Kester
- Quinn Temmel
- ROBATEL Industries
- COH Cranes
- Canadian Foundation for Innovation
- NSERC
- FRIB
- Roxana Ralea
- Many others...